



TUNIC



INSTRUCTION BOOKLET

TUNIC

Andrew Shouldice
 Kevin Regamey
 Eric Billingsley
 Terence Lee
 Janice Kwan

Illustrations
 ma-ko

Production
 Felix Kramer

Published By Finji

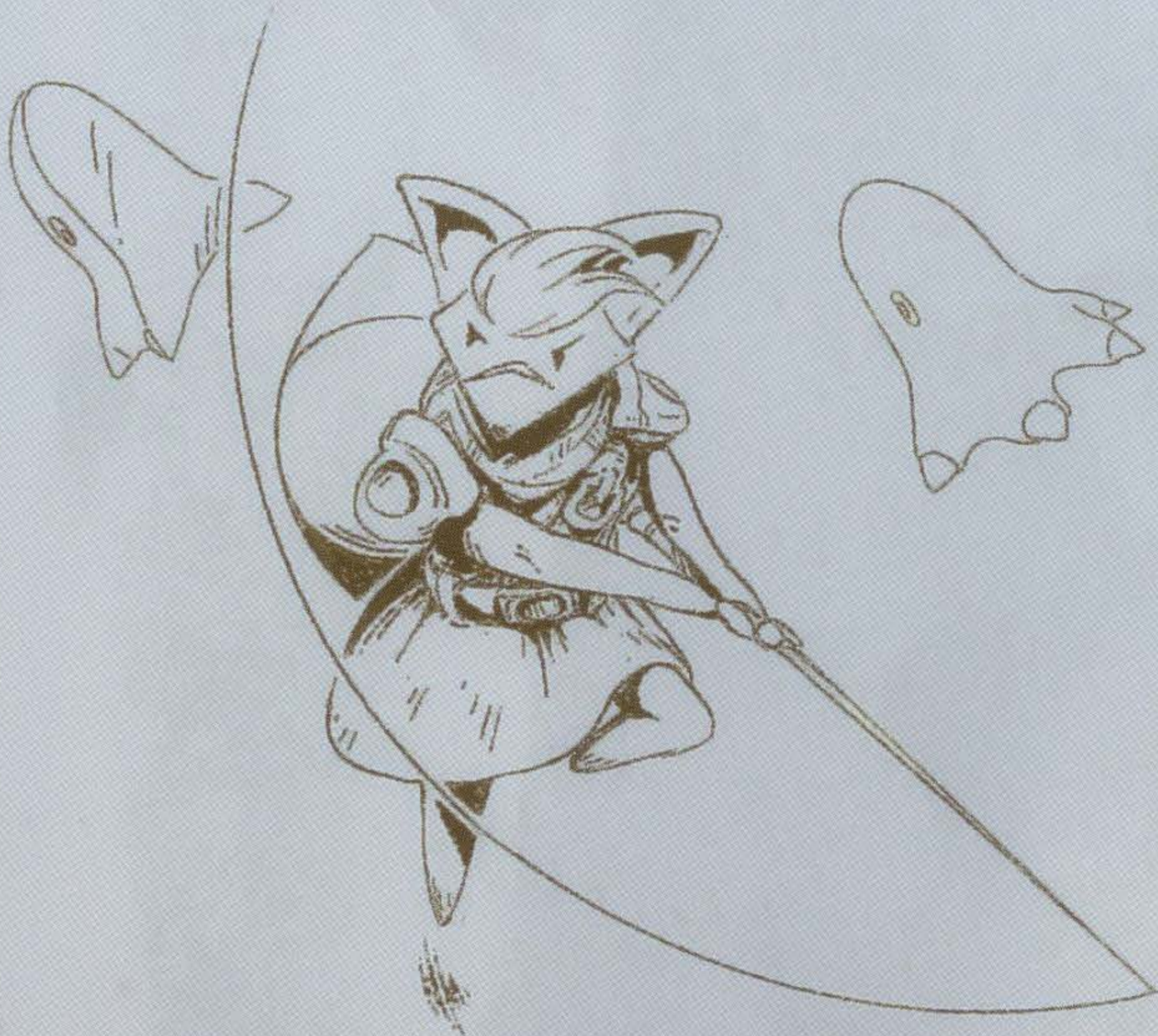

L I F
 E F O
 R M E
 D I S



Dear Player,

You've come a long way, haven't you? You've probably found a lot of secrets. Maybe you stumbled across the hidden trophy room; perhaps you even freed every fairy.

We hope you've had fun, but there's at least one more thing for you to do. If this is your final page, you should pay a visit to a certain someone and share your wisdom.





Thank you so much for playing.

Eric B
 Adam
 +
 Bix

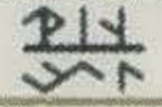

Keep this letter; you never know when it will be useful! Do not dispose of or eat this document.

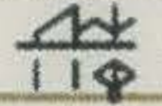

TABLE OF CONTENTS

The Story	3
Data Management	9
BEGINNING your Adventure	10
The Game Screen	11
Controls	12
Stamina	16
Items	17
Increasing Your Power	18
Death	19
  20	20
Hints and Clues	21
  23	23
Survival Tips	26

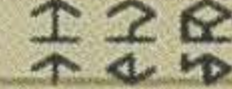
MAPS

West Garden	27
Overworld	28
Under the Well	29
Eastern Vault	31
Ruined Atoll	33
Frog's Domain	35
Quarry	38
Swamp	39
Cathedral	40
  41	41

Hidden Secrets	43
Memo Pages	52

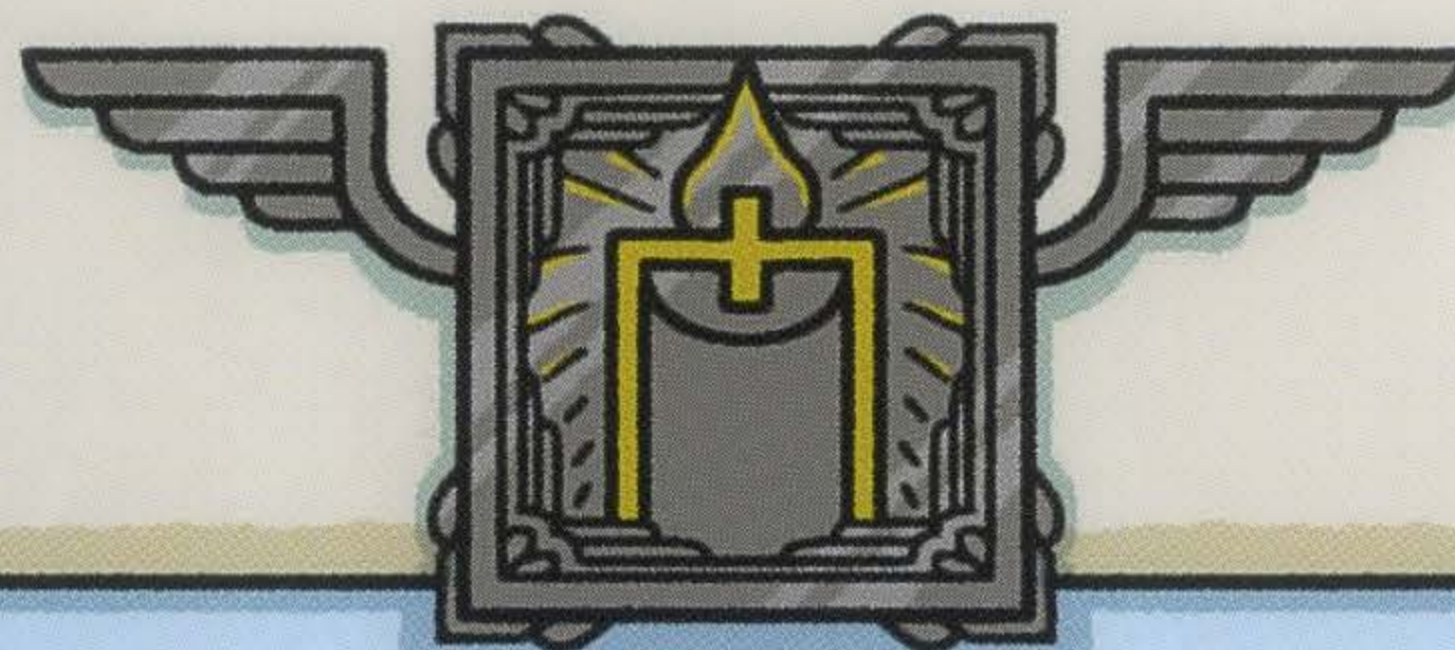

A LONG, LONG TIME AGO...

Civilization
 Holy Cross,

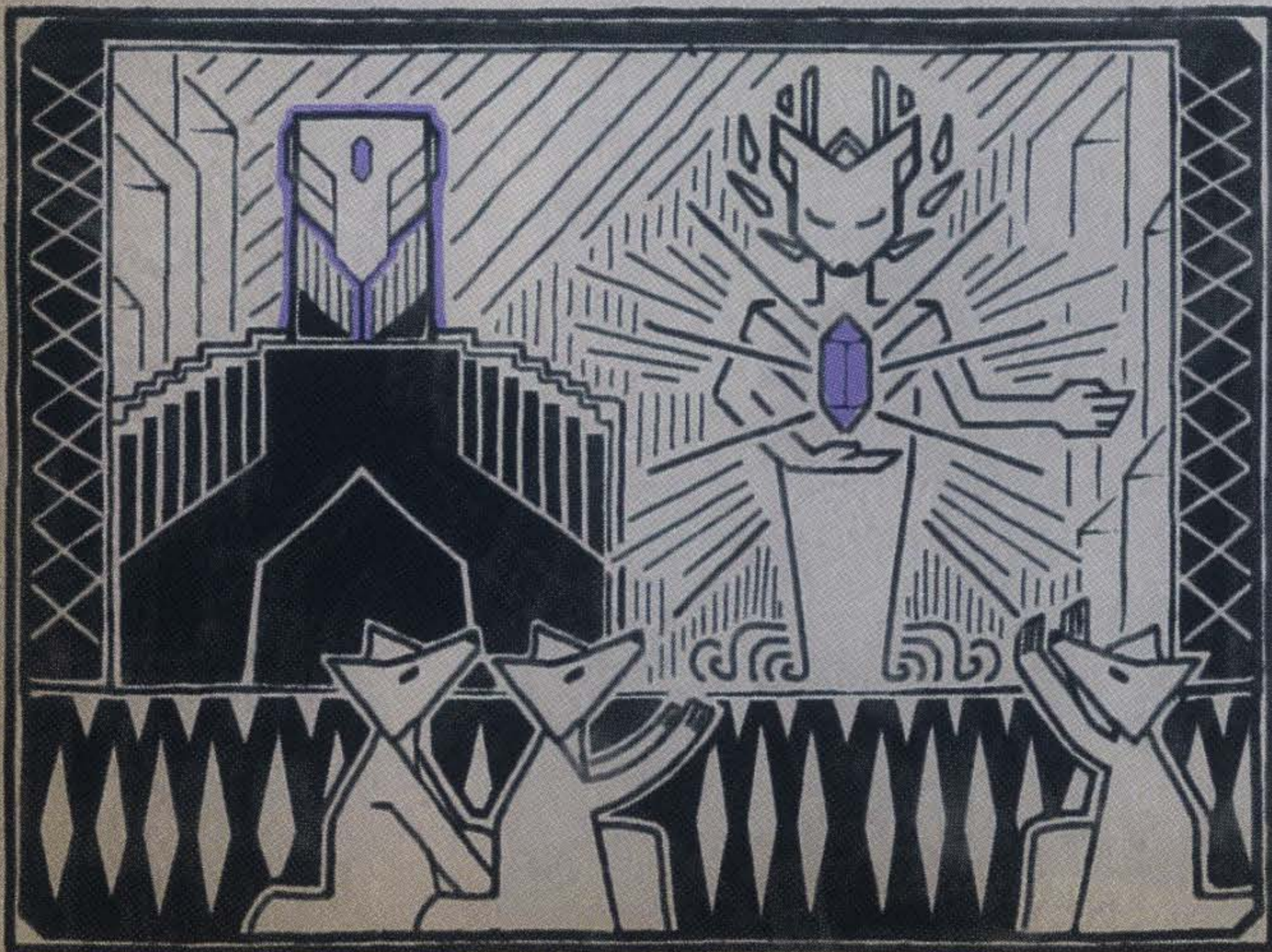

The Power To Defy Death.

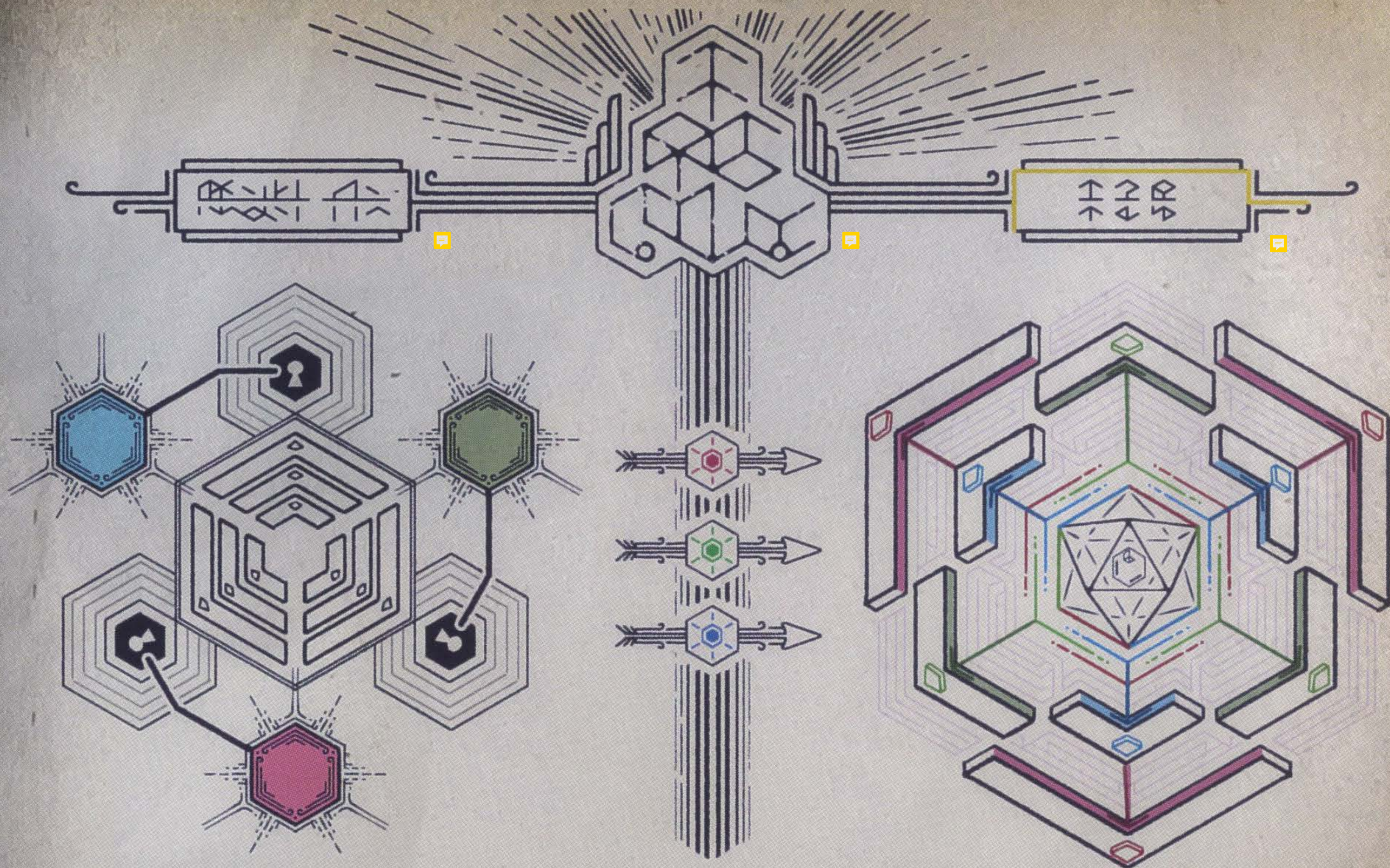

COVETED IN A
FOREST TEMPLE

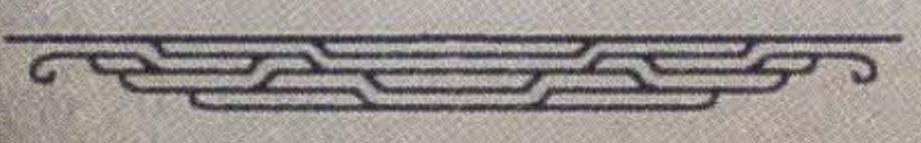

STOLEN TO THE
TOP OF THE SKY

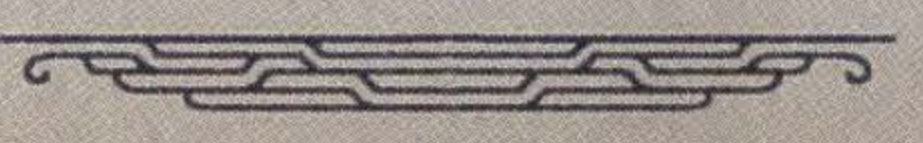

SEALED AT THE
ROOT OF THE WORLD

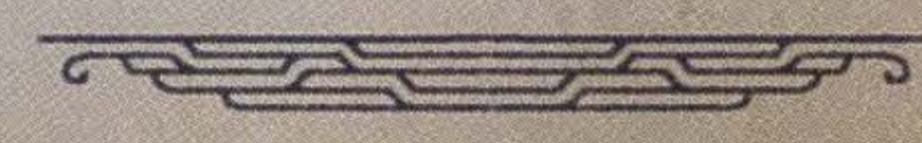

Again the same battle,
fought uncountable times!

ᠠᠨᠠᠭᠠᠢ ᠲᠤ ᠰᠠᠮᠤ ᠪᠠᠳᠤᠯᠤᠰᠤ,
ᠲᠤᠮᠤᠨᠠᠭᠤ ᠲᠤᠮᠤᠨᠠᠭᠤ ᠲᠤᠮᠤᠨᠠᠭᠤ
ᠲᠤᠮᠤᠨᠠᠭᠤ ᠲᠤᠮᠤᠨᠠᠭᠤ ᠲᠤᠮᠤᠨᠠᠭᠤ
ᠲᠤᠮᠤᠨᠠᠭᠤ ᠲᠤᠮᠤᠨᠠᠭᠤ ᠲᠤᠮᠤᠨᠠᠭᠤ

ᠲᠤᠮᠤᠨᠠᠭᠤ ᠲᠤᠮᠤᠨᠠᠭᠤ ᠲᠤᠮᠤᠨᠠᠭᠤ
ᠲᠤᠮᠤᠨᠠᠭᠤ ᠲᠤᠮᠤᠨᠠᠭᠤ ᠲᠤᠮᠤᠨᠠᠭᠤ
ᠲᠤᠮᠤᠨᠠᠭᠤ ᠲᠤᠮᠤᠨᠠᠭᠤ ᠲᠤᠮᠤᠨᠠᠭᠤ

ᠲᠤᠮᠤᠨᠠᠭᠤ Heir-To-The-Heir, ᠲᠤᠮᠤᠨᠠᠭᠤ
ᠲᠤᠮᠤᠨᠠᠭᠤ ᠲᠤᠮᠤᠨᠠᠭᠤ ᠲᠤᠮᠤᠨᠠᠭᠤ
ᠲᠤᠮᠤᠨᠠᠭᠤ ᠲᠤᠮᠤᠨᠠᠭᠤ ᠲᠤᠮᠤᠨᠠᠭᠤ
ᠲᠤᠮᠤᠨᠠᠭᠤ ᠲᠤᠮᠤᠨᠠᠭᠤ ᠲᠤᠮᠤᠨᠠᠭᠤ

ᠲᠤᠮᠤᠨᠠᠭᠤ ᠲᠤᠮᠤᠨᠠᠭᠤ ᠲᠤᠮᠤᠨᠠᠭᠤ
ᠲᠤᠮᠤᠨᠠᠭᠤ ᠲᠤᠮᠤᠨᠠᠭᠤ ᠲᠤᠮᠤᠨᠠᠭᠤ
ᠲᠤᠮᠤᠨᠠᠭᠤ ᠲᠤᠮᠤᠨᠠᠭᠤ ᠲᠤᠮᠤᠨᠠᠭᠤ



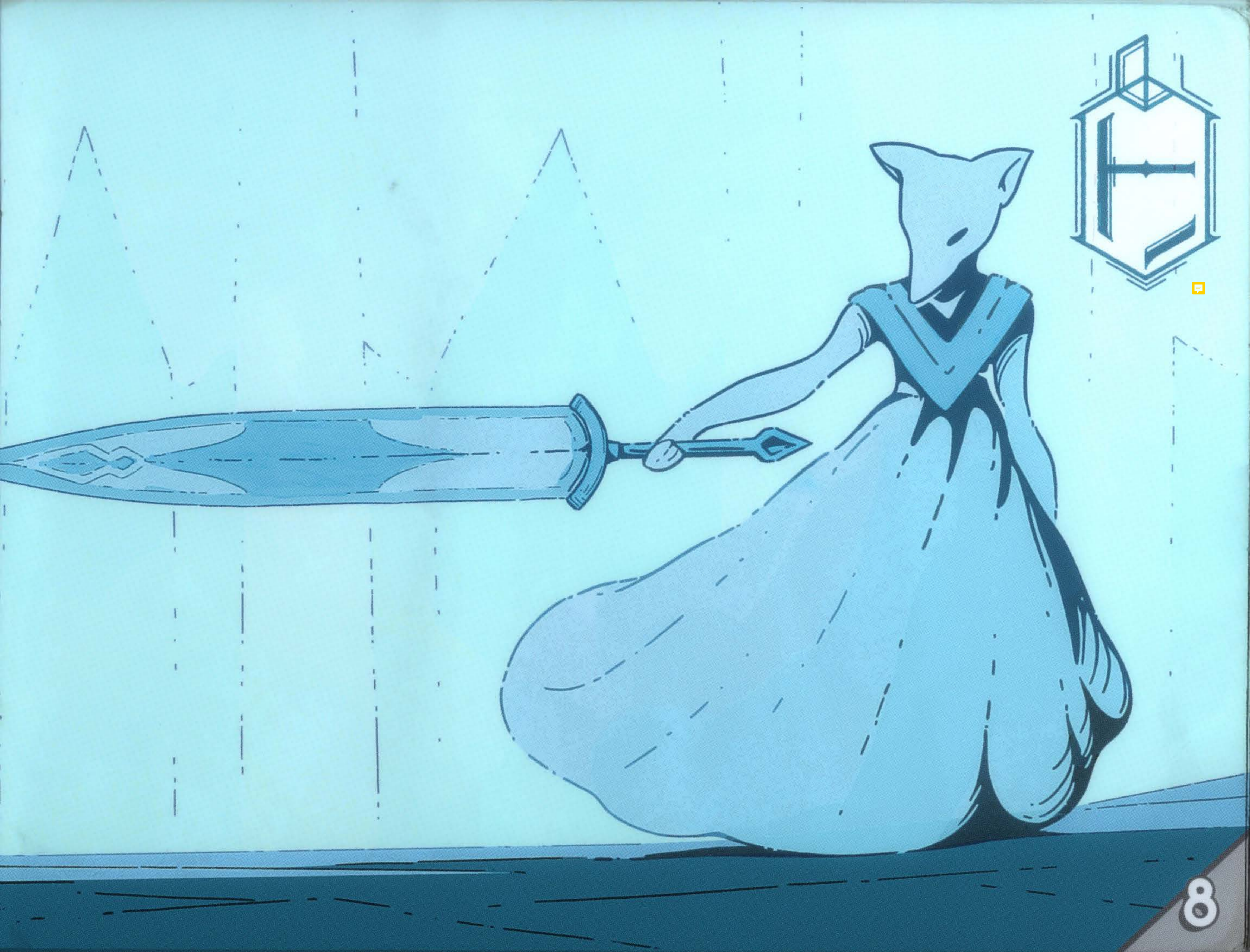

Data Management



CONTINUE	
NEW GAME	
OPTIONS	
LOAD GAME	

OPTIONS

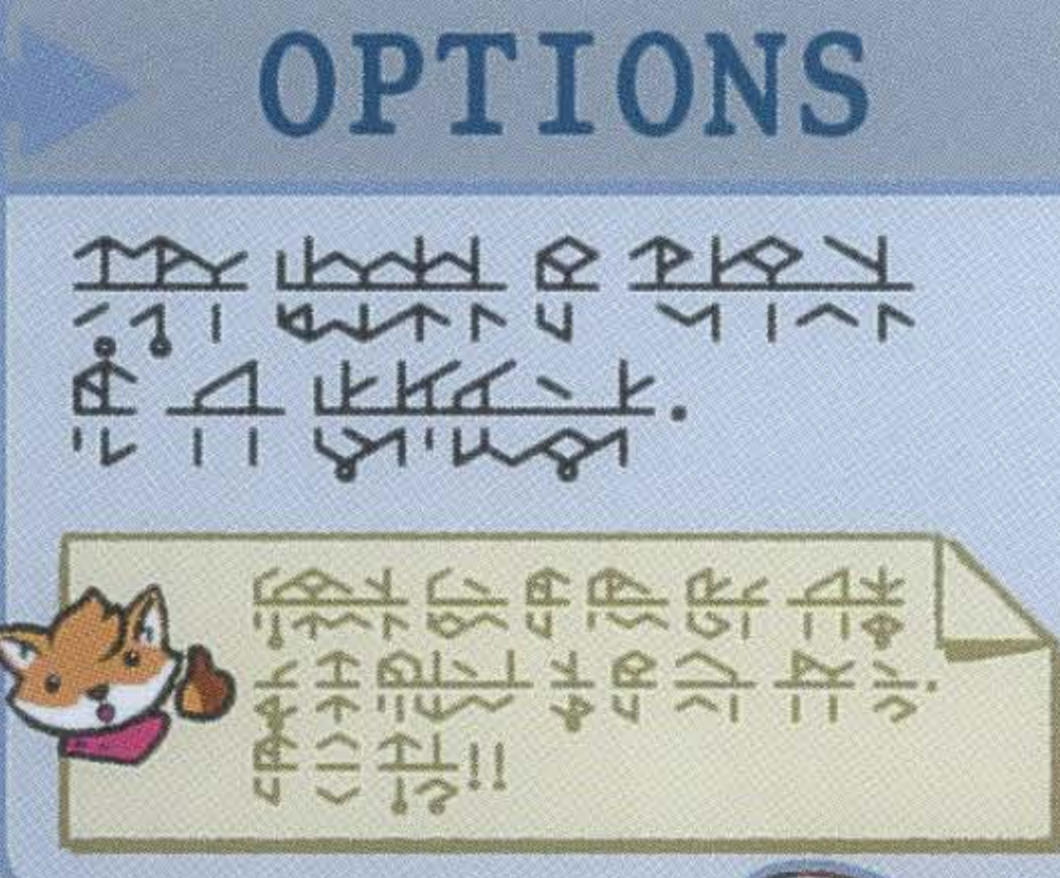

SAVE DATA





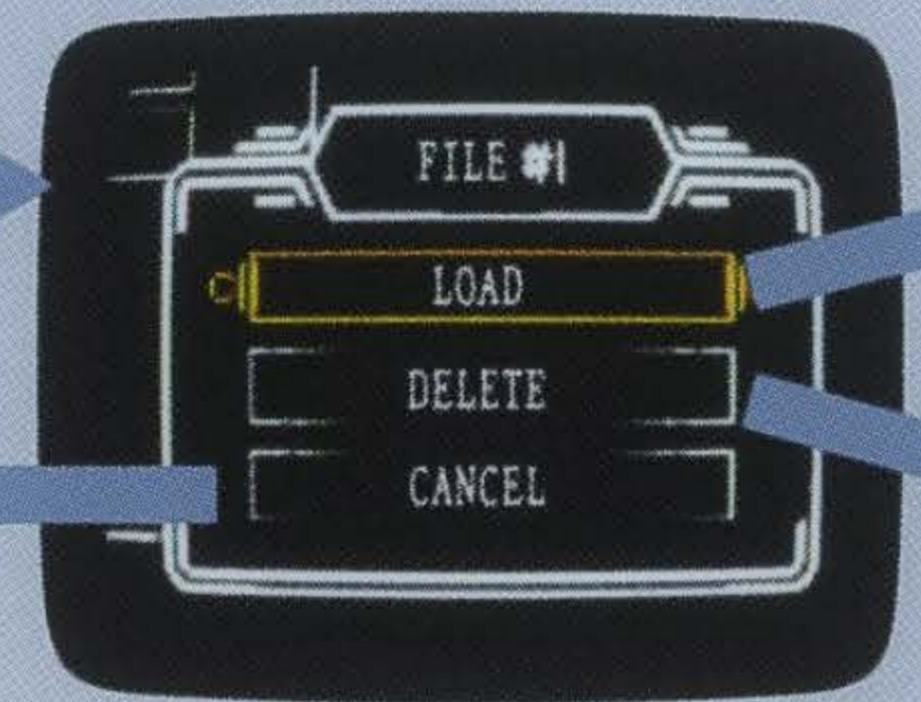
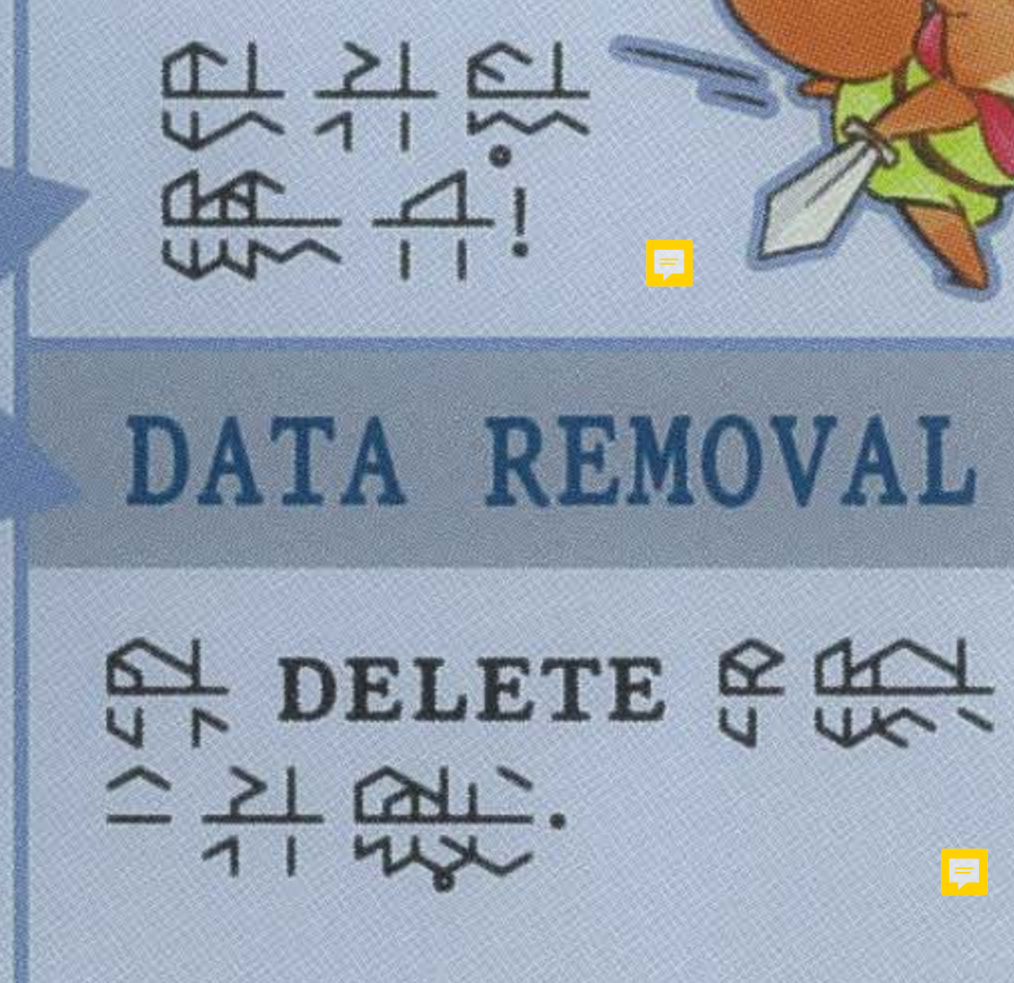

DATA REMOVAL







THE GAME SCREEN







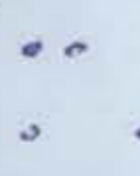









PRIZE / TREASURE

 HEALTH-POINTS
 STAMINA-POINTS
 MAGIC-POINTS

READIED EQUIPMENT



MAGIC POTION



FOCUS PREVIEW

everything hurts way more when I'm tired

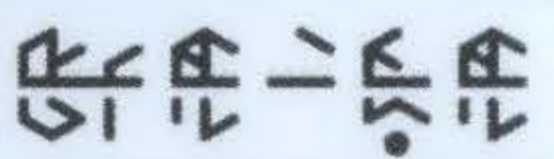
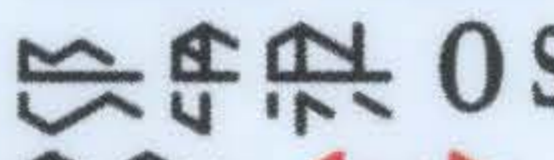

IMPORTANT!



STAMINA-POINTS!
 0 SP



ASPIRE

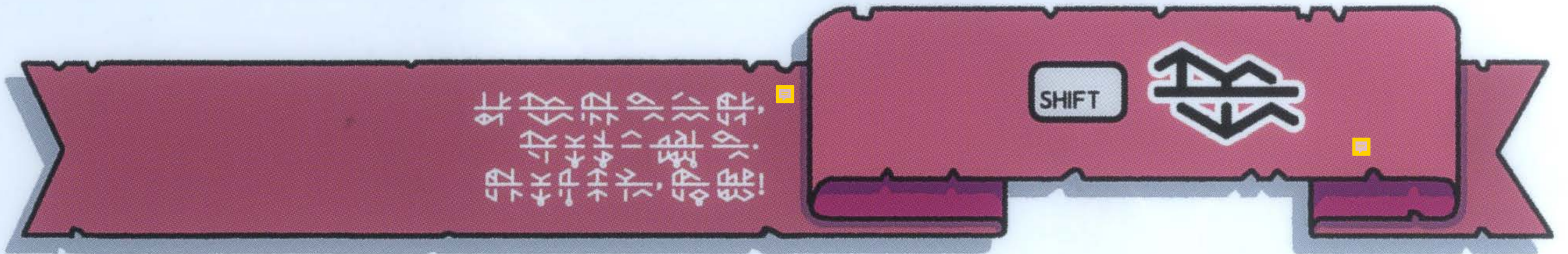



水 火 風 雷 土 木
 火 水 雷 土 木 風
 雷 土 木 風 火 水

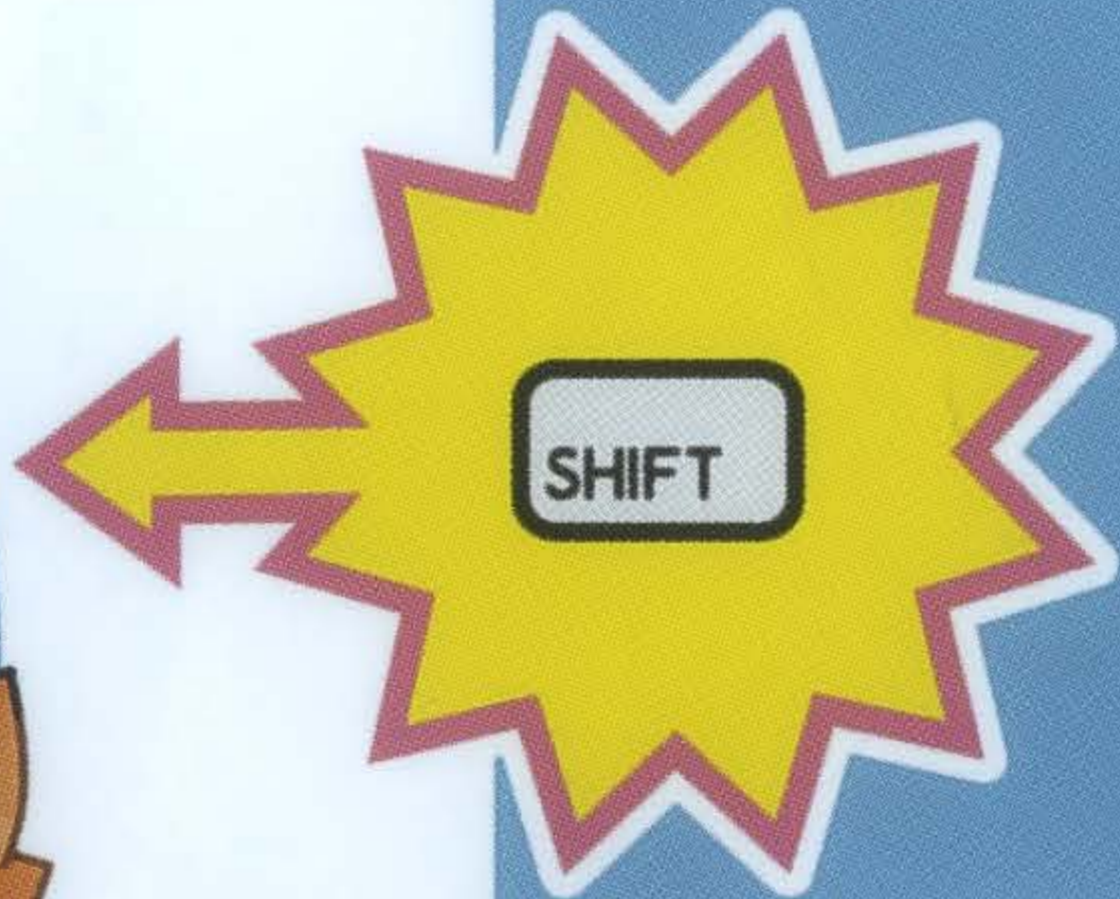

FACE YOUR ADVERSARIES

水 火 風 雷 土 木
 火 水 雷 土 木 風
 雷 土 木 風 火 水

水



FOCUS & EVADE

水 火 風 雷 土 木
 火 水 雷 土 木 風



FOCUS & BLOCK

水 火 風 雷 土 木
 火 水 雷 土 木 風



安全

安全
安全
安全

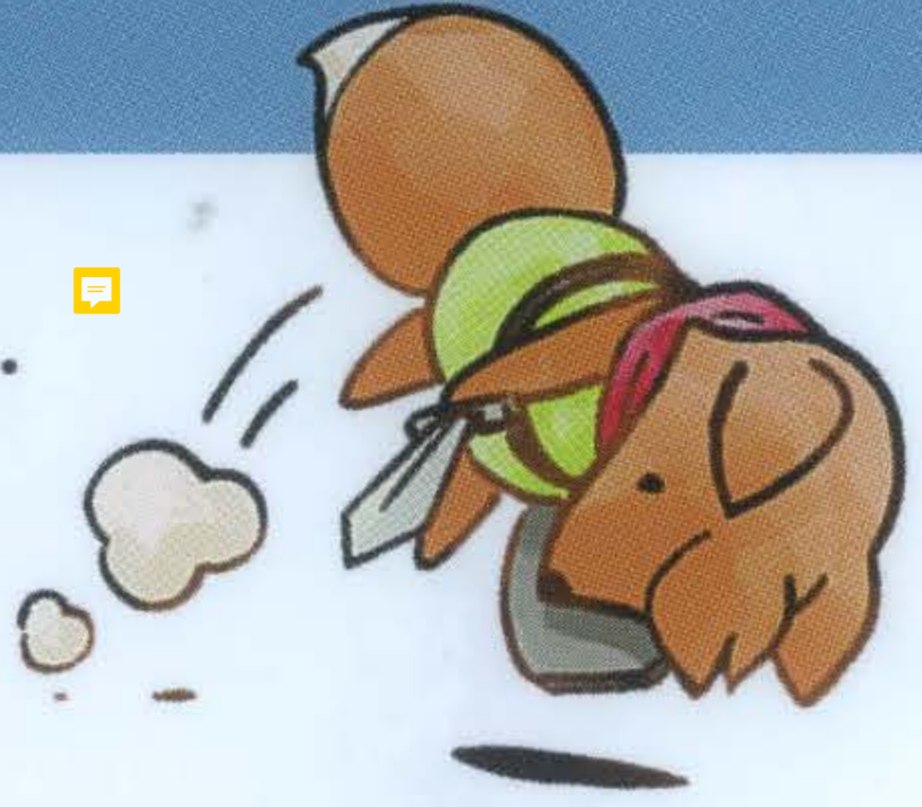

安全
安全
安全



FLASHING



0%

危险
危险
危险



危险!





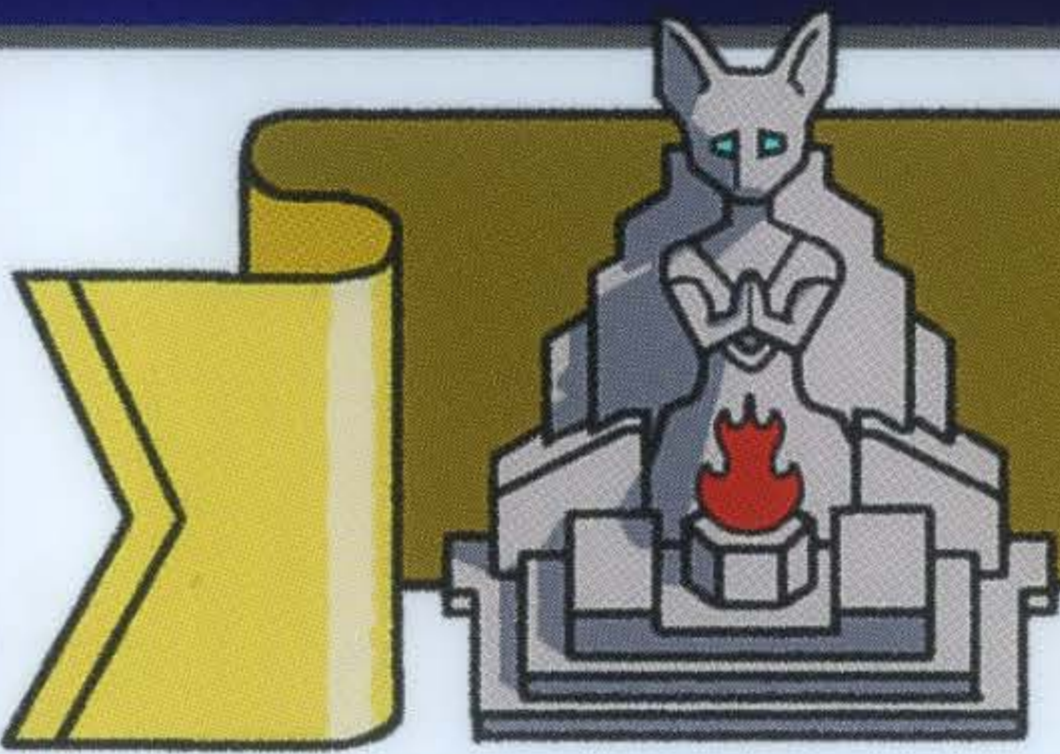

- ⚠ No Safety
- ⚠ Low Stability
- ⚠ Hurt More

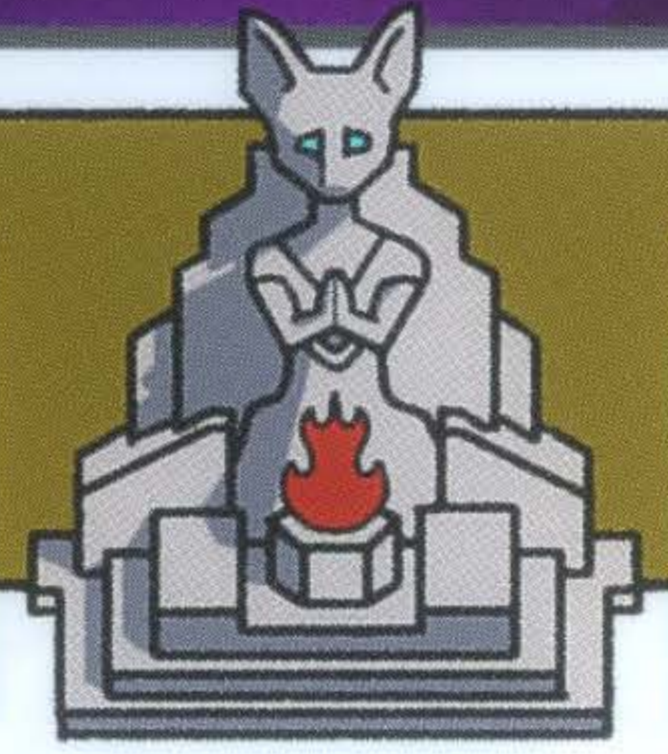
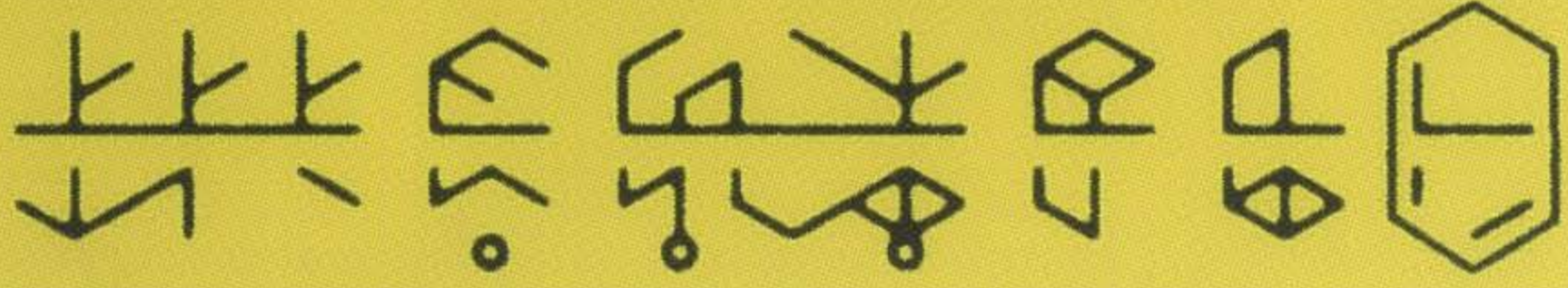
安全	EVASIVE	DMG. TAKEN	BLOCK	STABILITY	SPECIAL TECH
	moment of safety	100%	✓	normal	✓
	vulnerable	150%	✗	low	✗

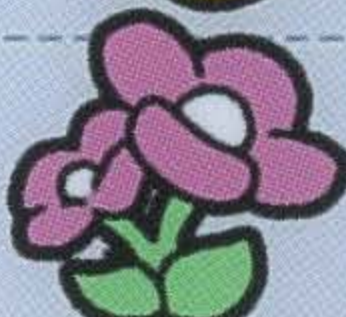

If you seek to increase your power...



		1	2	3
	ATT	100	150	200
	DEF	100	150	200
	HP	200	250	300
	Potion	100	300	1000
	???	300	???	???
	???	???	???	???

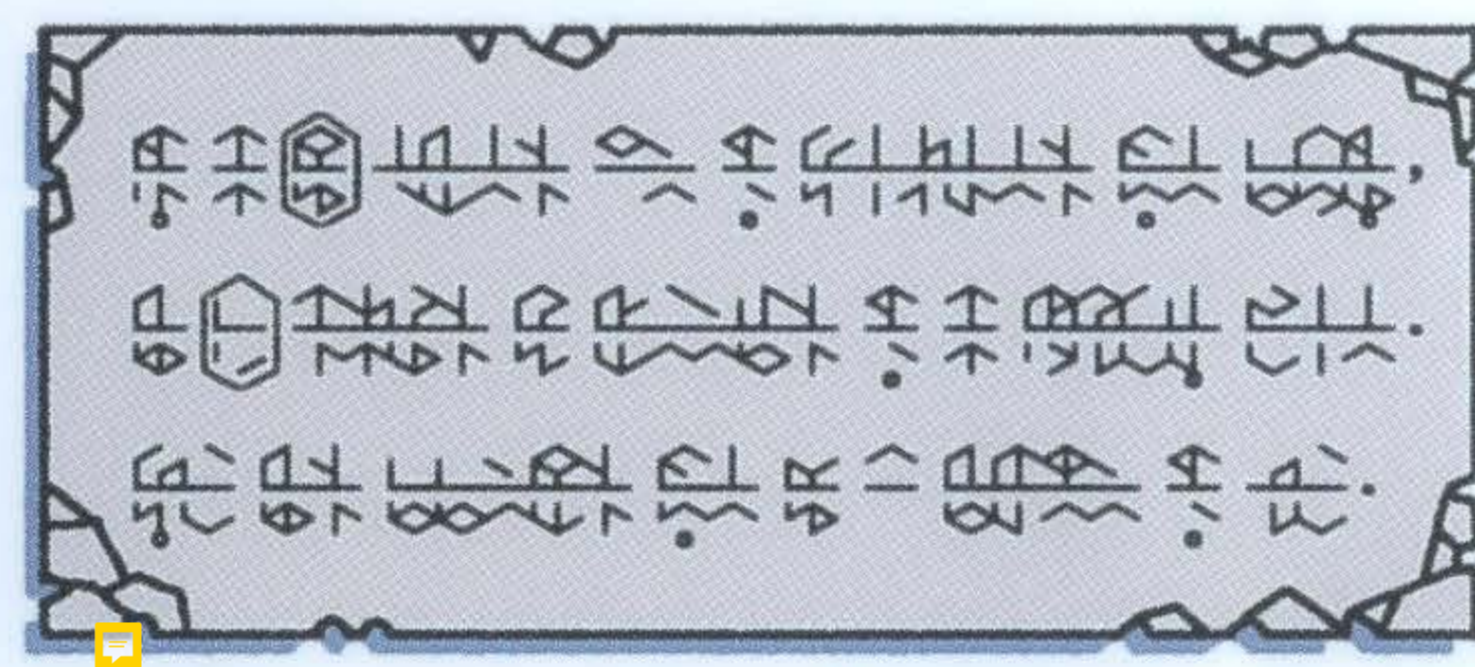

TAB



OH NO!



HEALTH-POINTS!

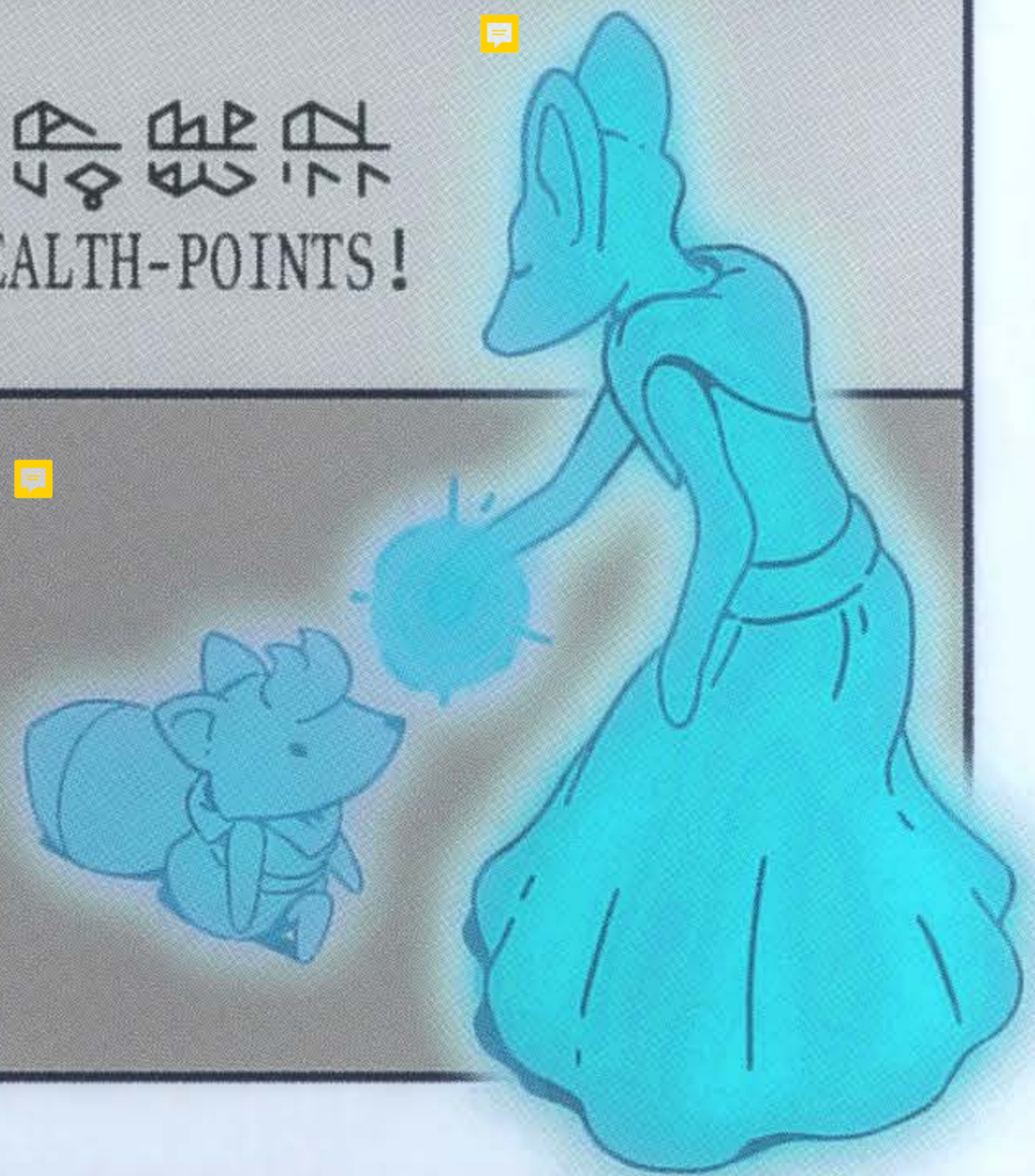

!?!? !

~~~~~



ECHO-OF-SELF.

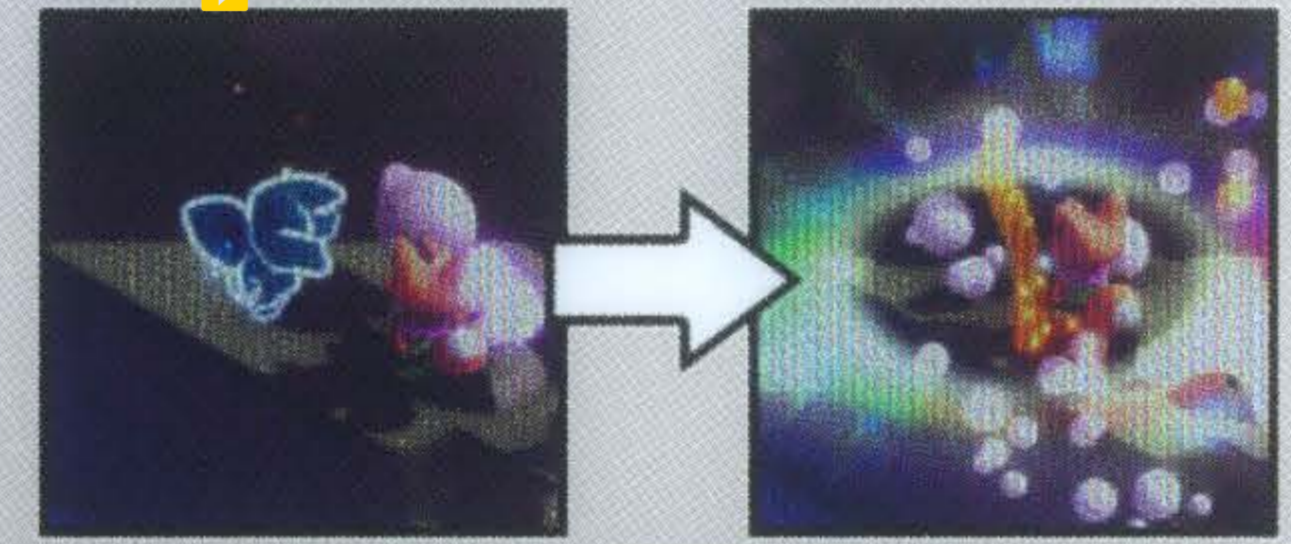

~~~~~

"YOU CAN DO IT!"



~~~~~

Try to be this strong

ATT  
3

DEF  
3

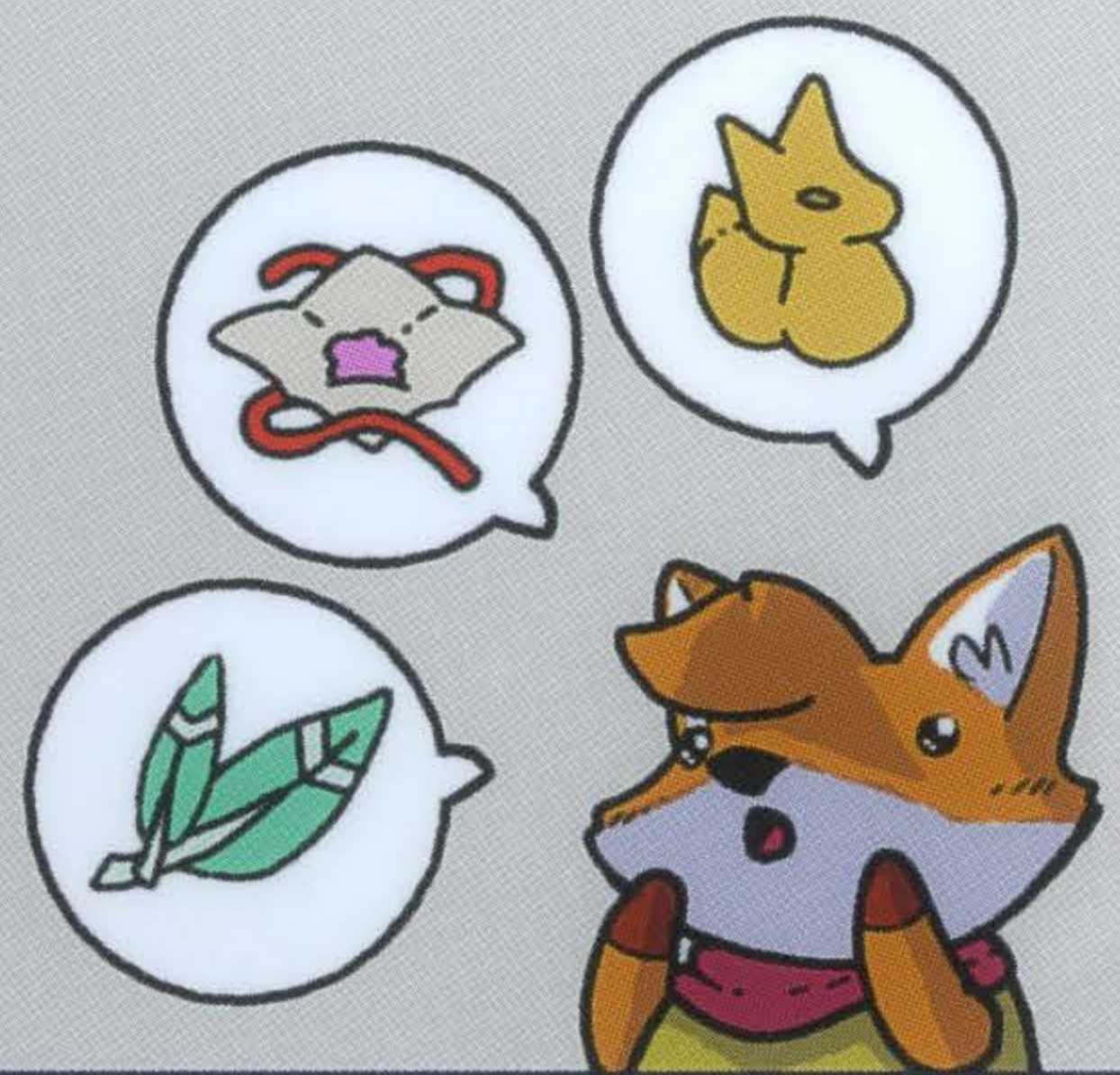



CYAN PERIL RING

DEF PERIL



INVERTED ASH

MP HP



LUCKY CUP

(15%)



MUFFLING BELL

...

51

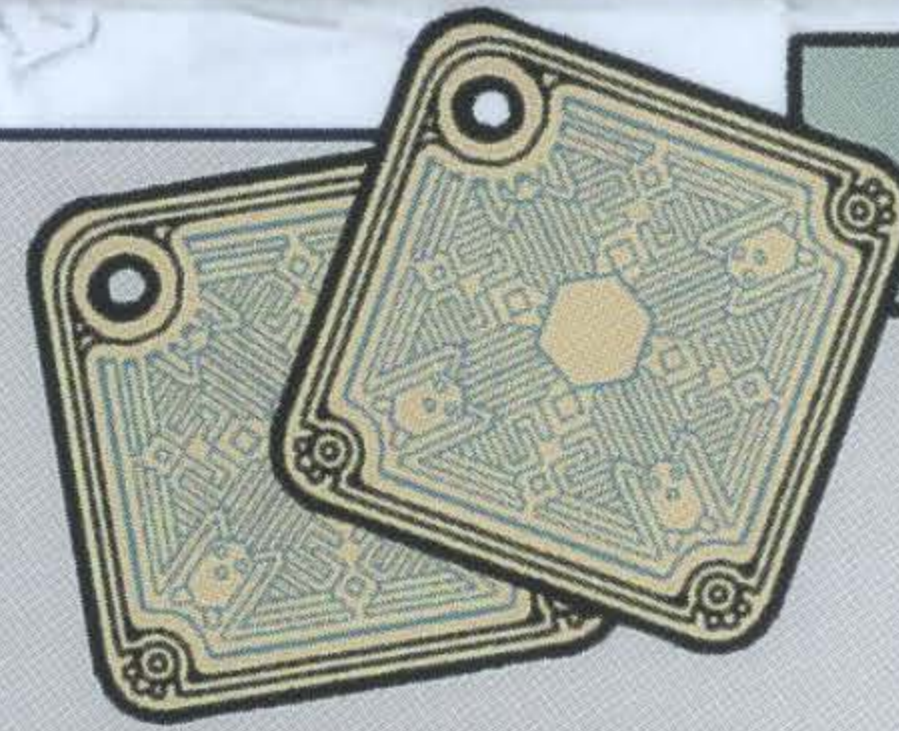

米

...



1. ...

2. ... ( )

3. ...

米米米



...

5

4

3

2

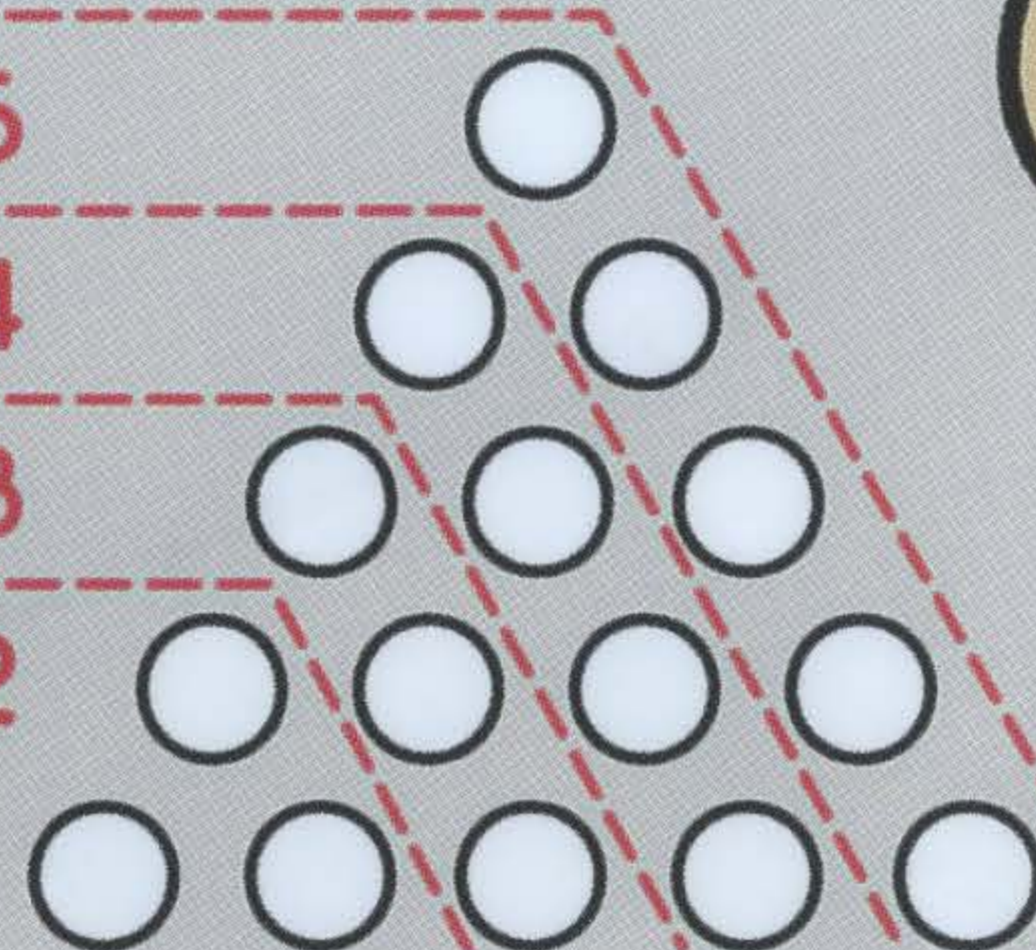

...

# HELP!

## HINTS AND CLUES

Handwritten symbols and characters at the top right of the page.



THE TEMPLE 3 KEYS

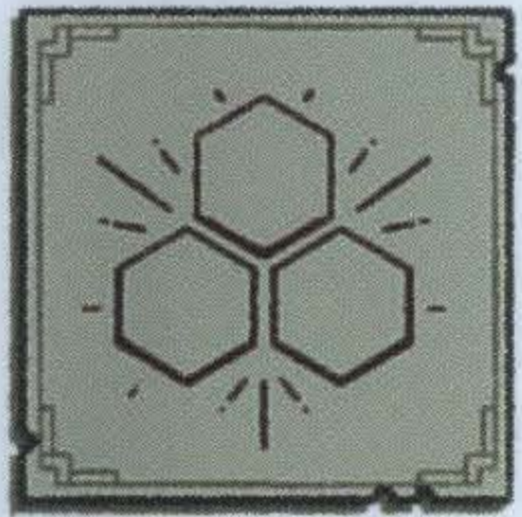

3 KEYS

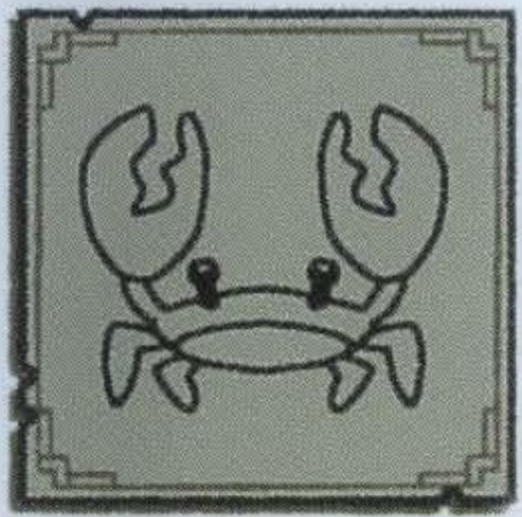

THE RUINED ATOLL?



P.49

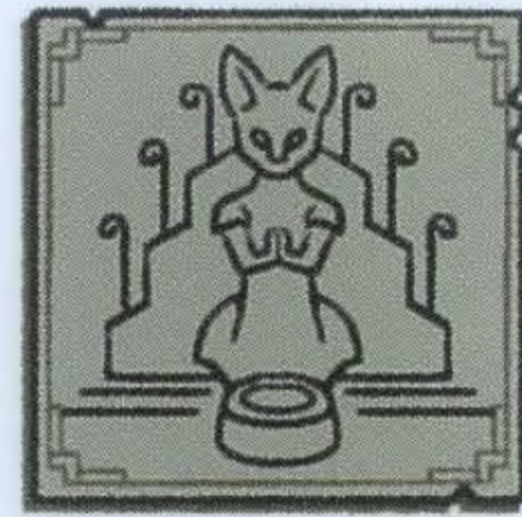

CHECK-POINT «DEAD»!

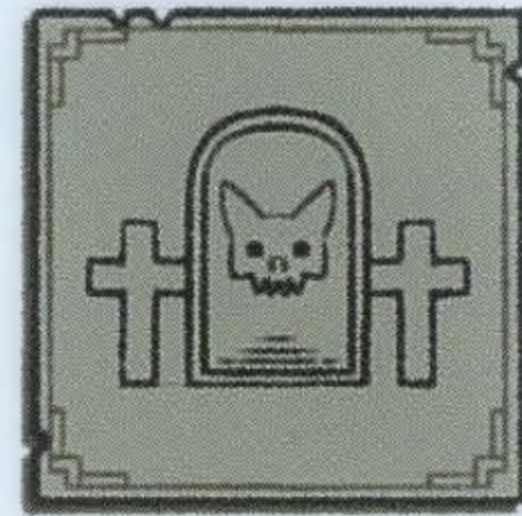

OLD BURYING GROUND



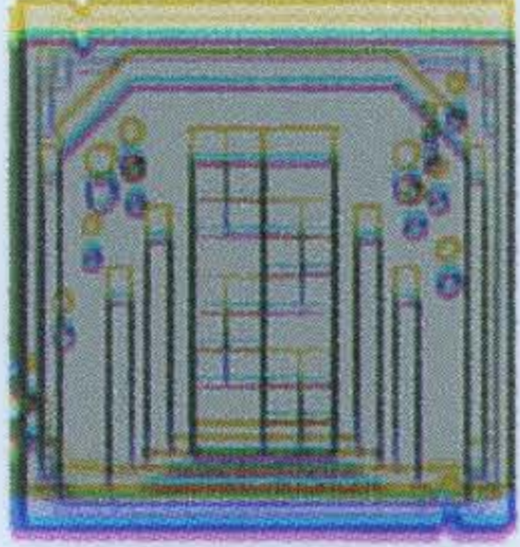

DOOR IN THE MOUNTAINS?  
P. 47

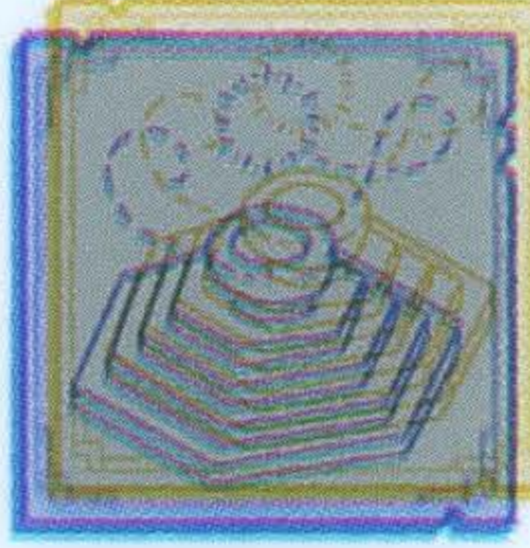

FAIRIES?  
P. 47

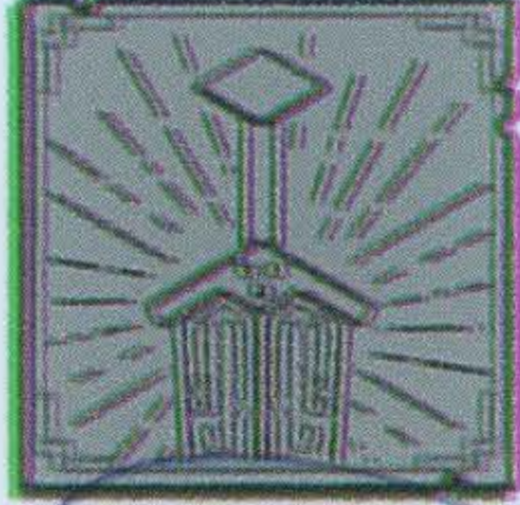

THE HERO'S GRAVE



22

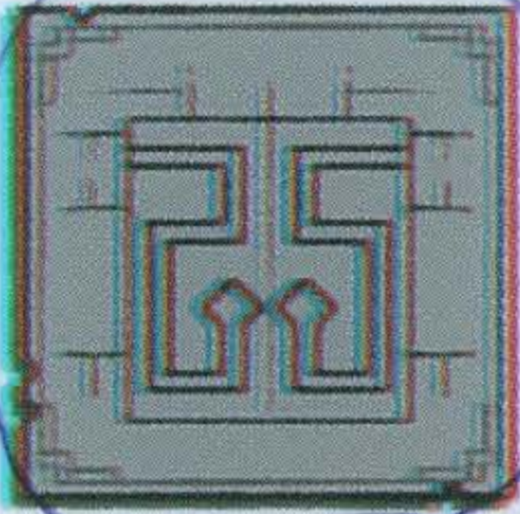

HOLY CROSS

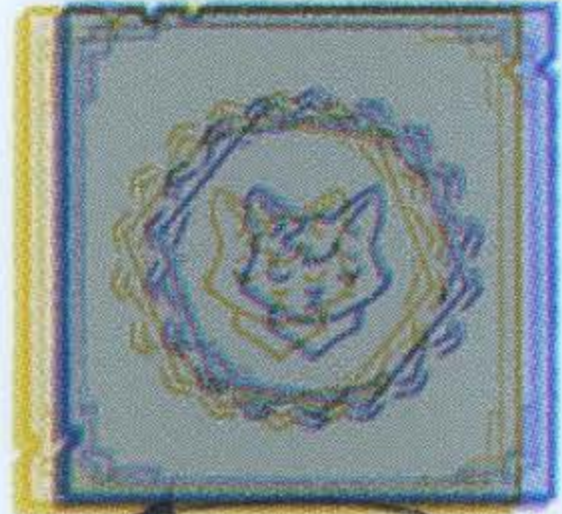

CAT

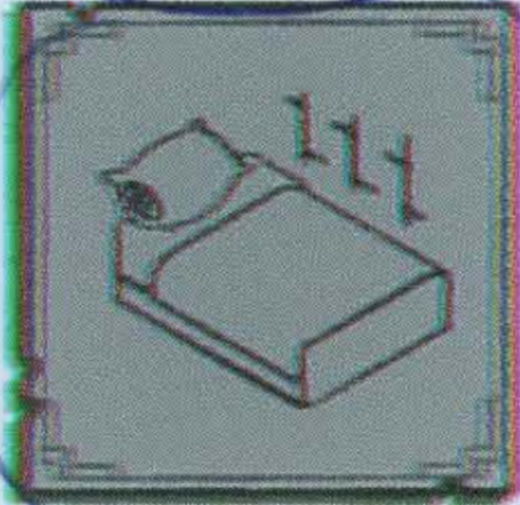

BOOK



TROPHY

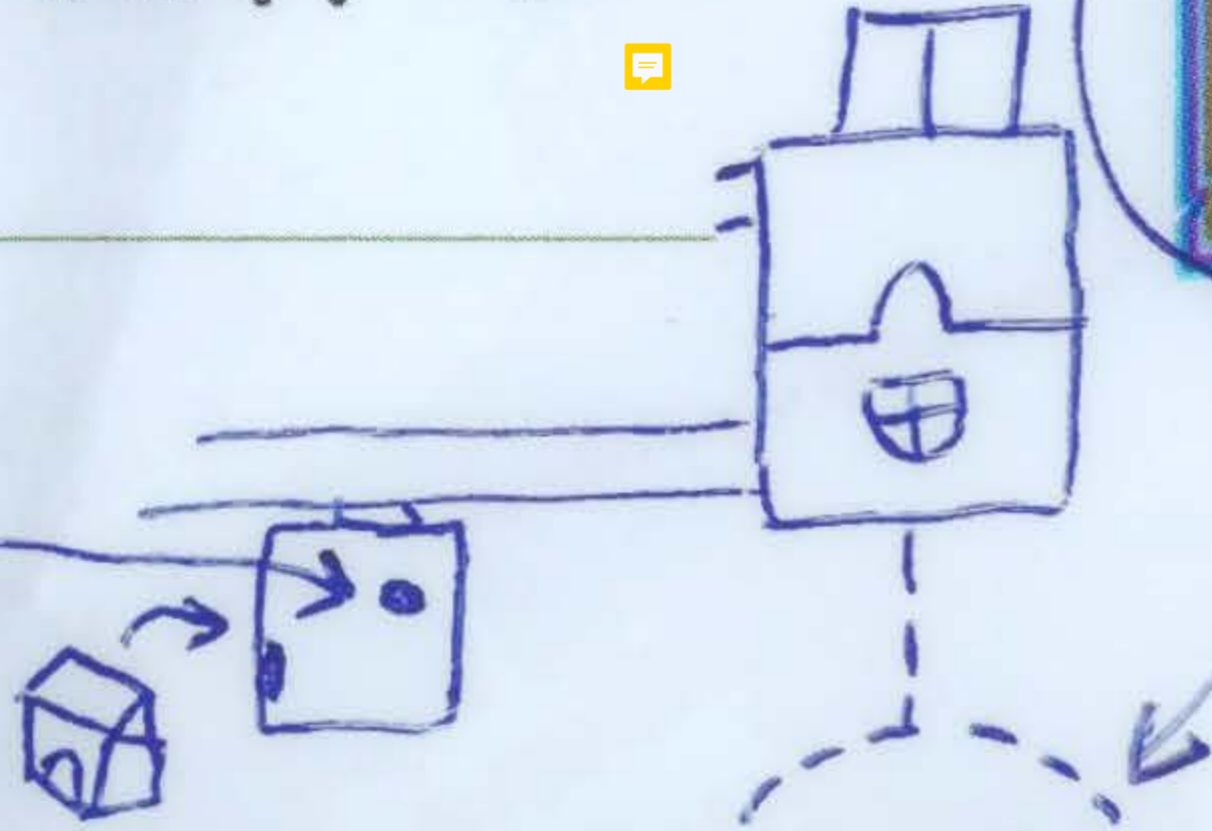

5R 6R 6R 6R  
 6R 6R 6R 6R  
 Door in the Mountains  
 6R 6R 6R 6R...

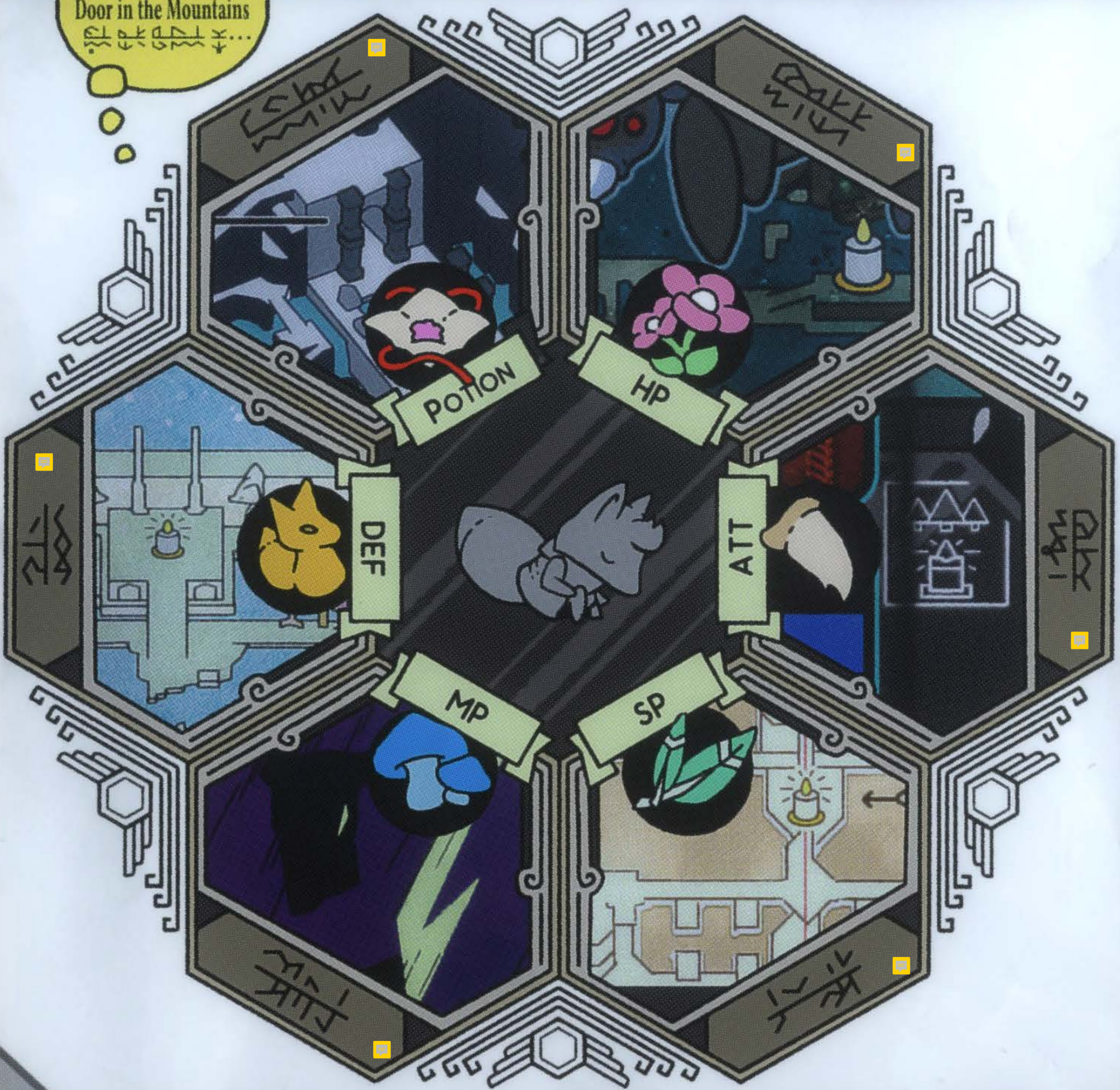

6R 6R 6R 6R  
 6R 6R 6R 6R  
 6R 6R 6R 6R

6R 6R, 6R 6R 6R 6R  
 6R 6R, 6R & 6R  
 6R 6R 6R 6R 6R 6R  
 6R 6R 6R 6R 6R 6R





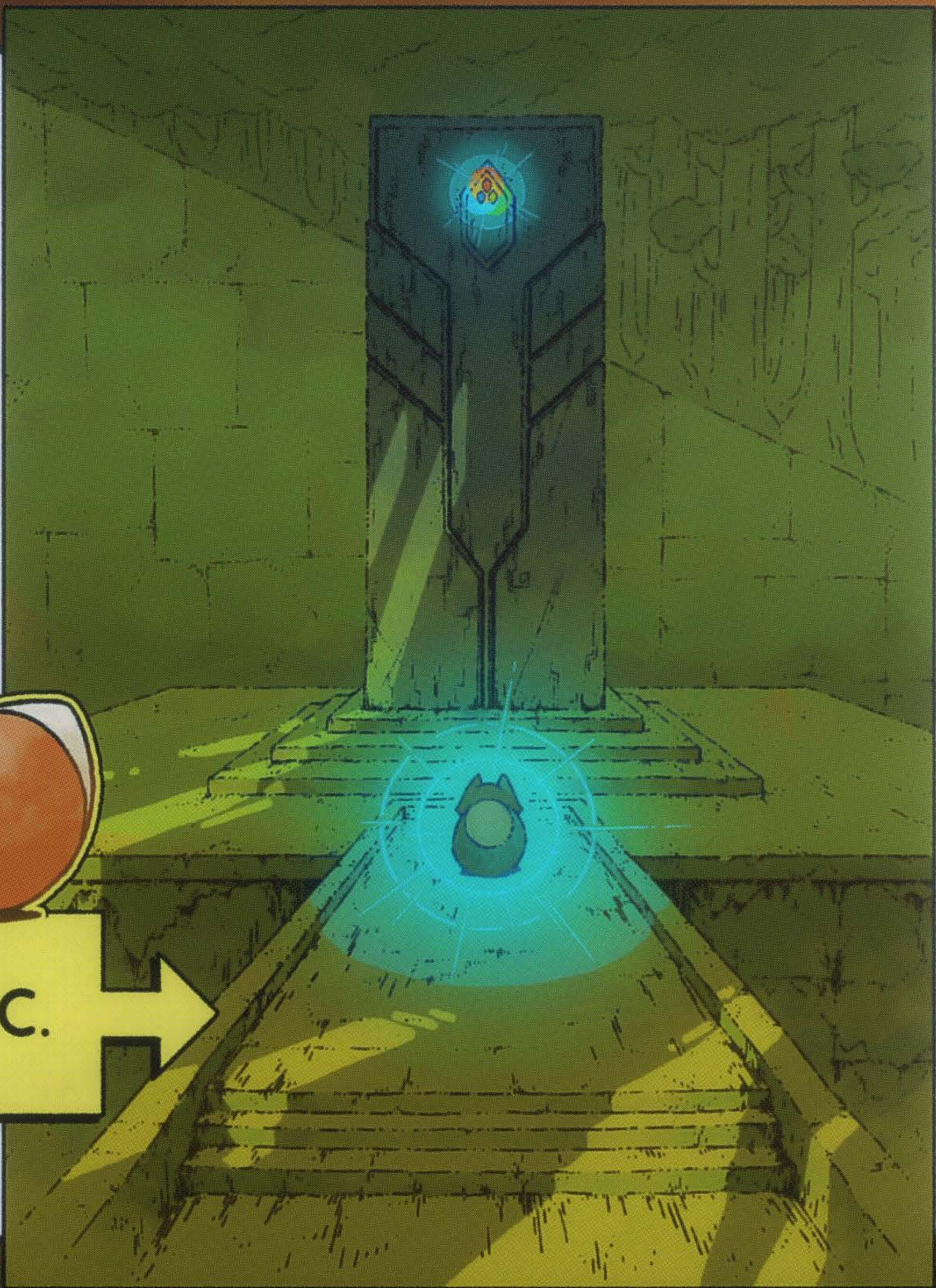
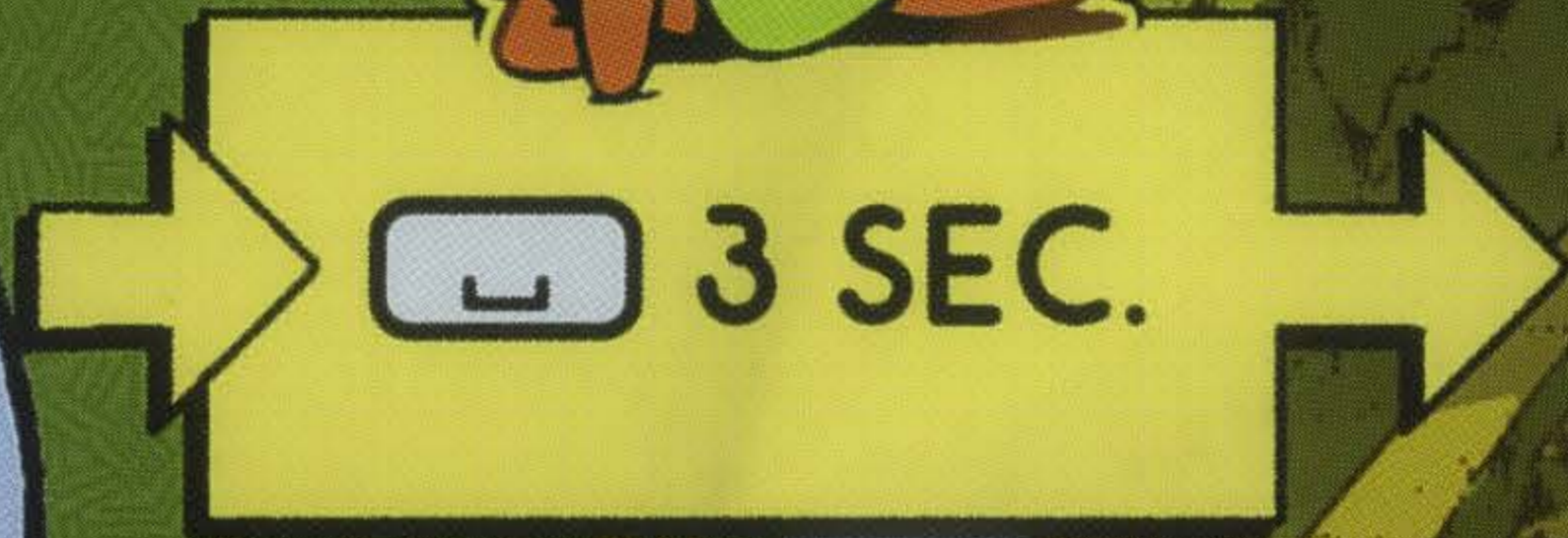
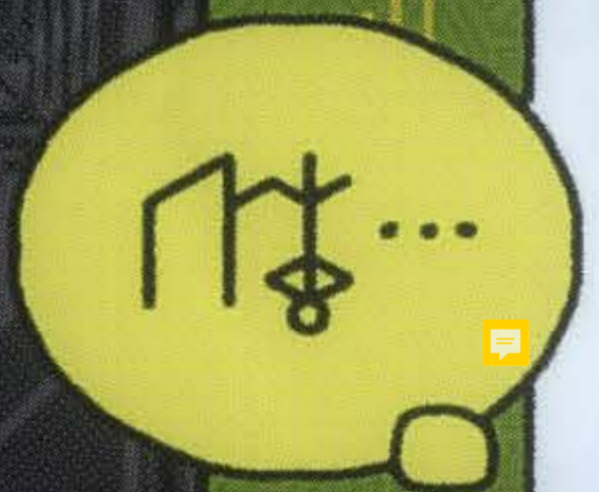
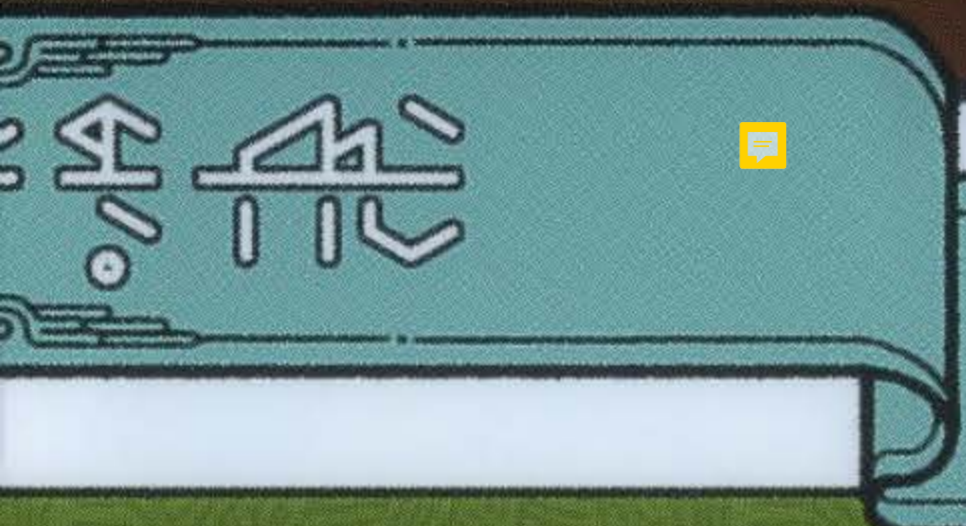

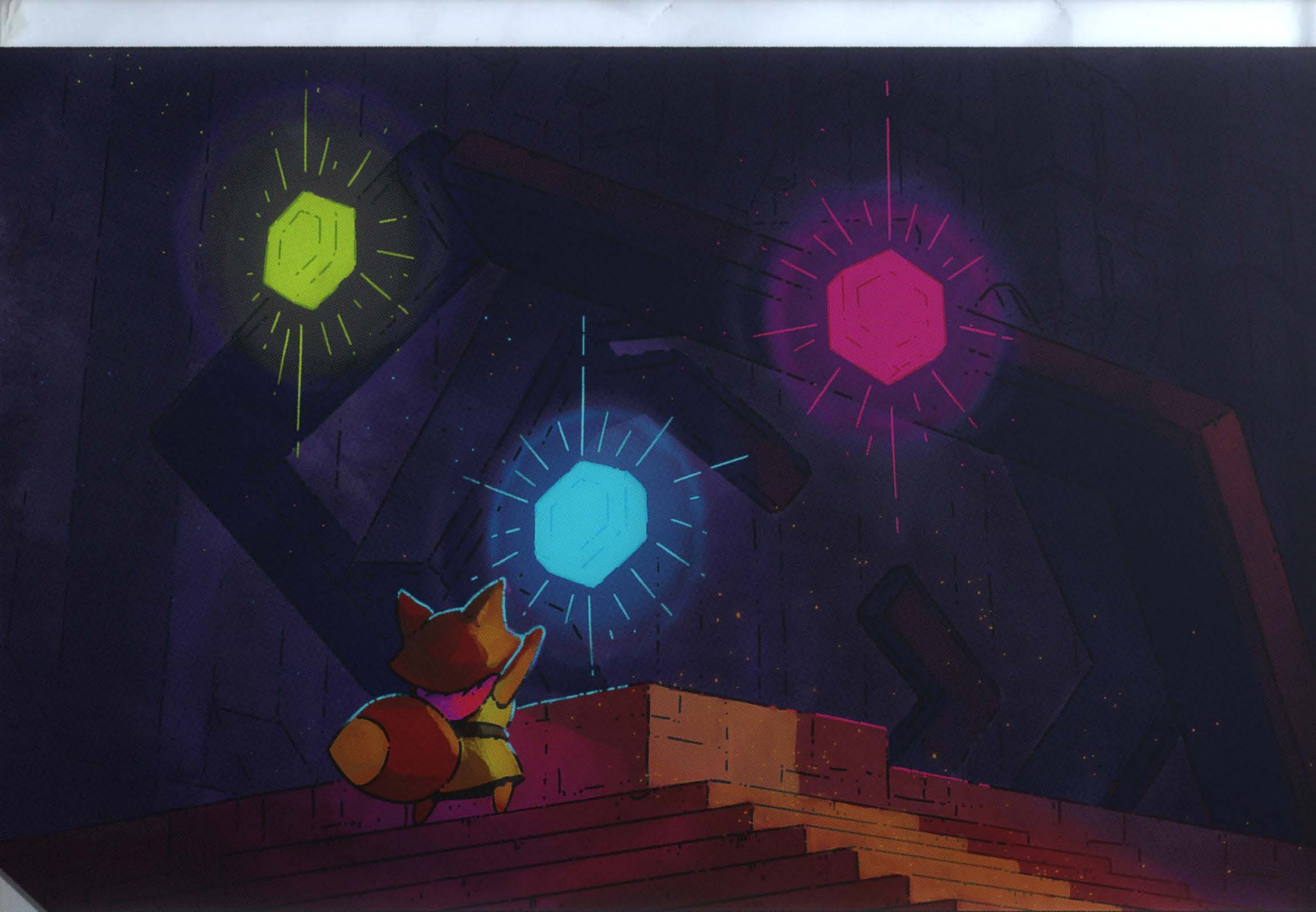

# SURVIVAL TIPS

## KEEP AN EYE ON YOUR BARS!



HP



EXTRA DAMAGE!



STAMINA-POINTS



## TIRED ALL THE TIME?

STAMINA-POINTS

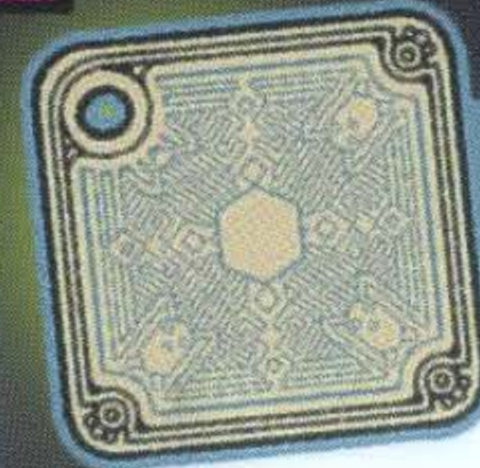

MAP



MAP



20



## USE YOUR ITEMS

USE YOUR ITEMS



Extra BOMBS for some reason? You must like using them!

## USE SPECIAL TECHNIQUES

USE SPECIAL TECHNIQUES



NOTE: STAMINA-POINTS



## CHECK THE MAP

CHECK THE MAP



## FAIRIES

Curious pieces of the wall that have come to life. They seem intent on stopping you.

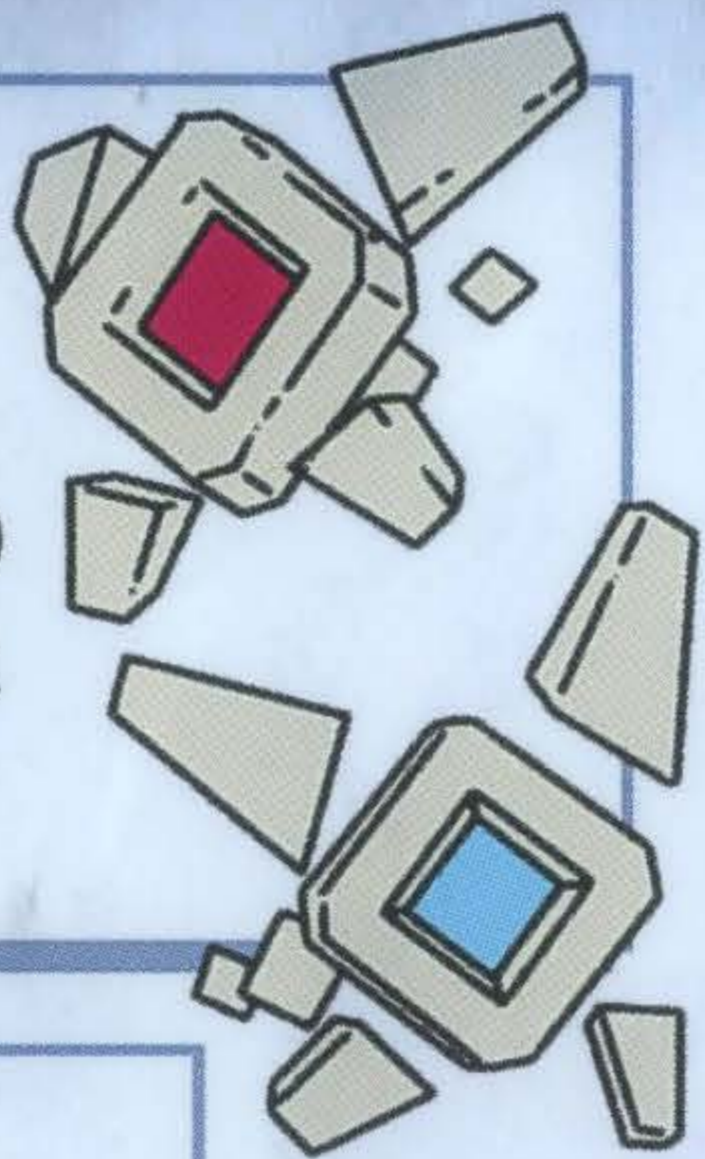

## CHOMPIGNOM

Always hungry. It runs fast but can't turn very quickly. Dangerous as a family!

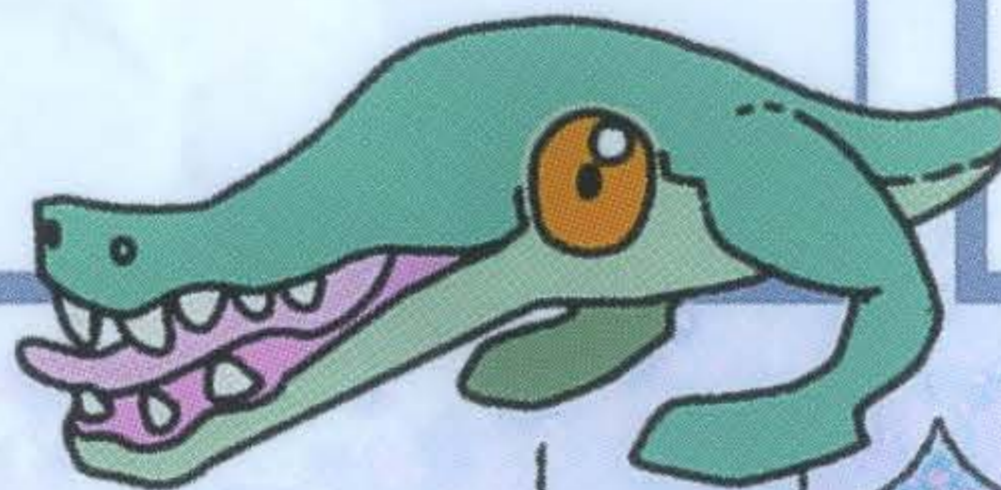

## RUDELING

Ghost of a soldier who has forgotten why they fight. Follows orders but has no soul.

## BOSS: ???

Blocks the way to the belltower. Will kill you.

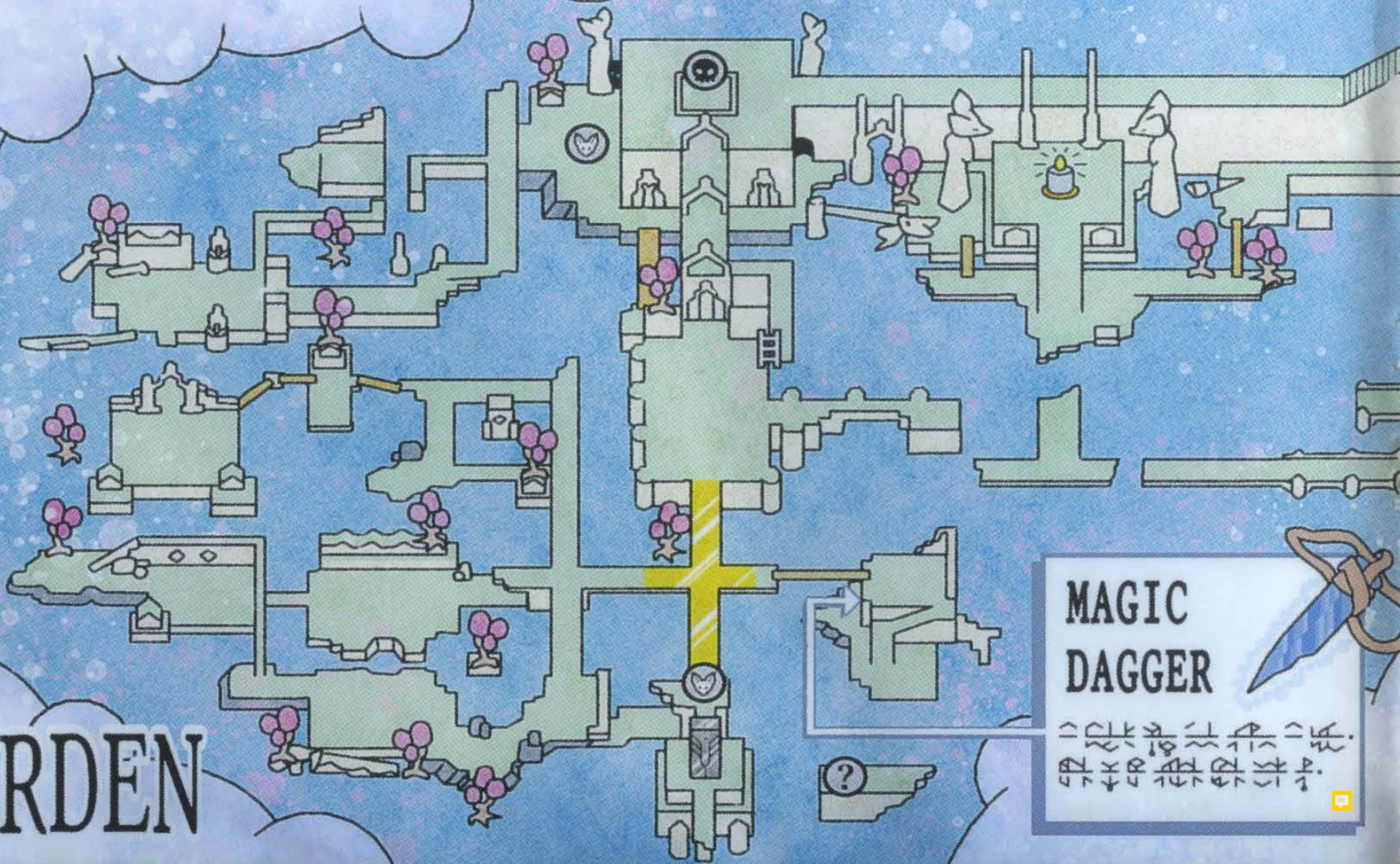
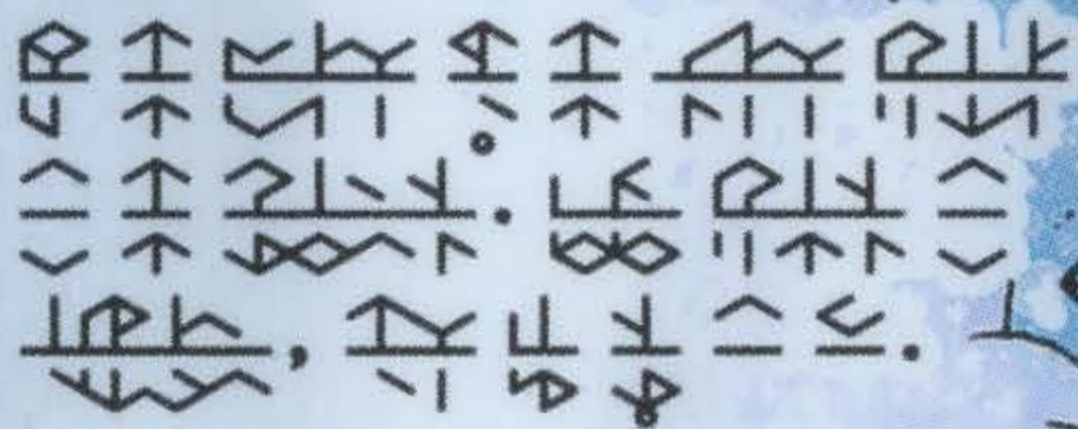
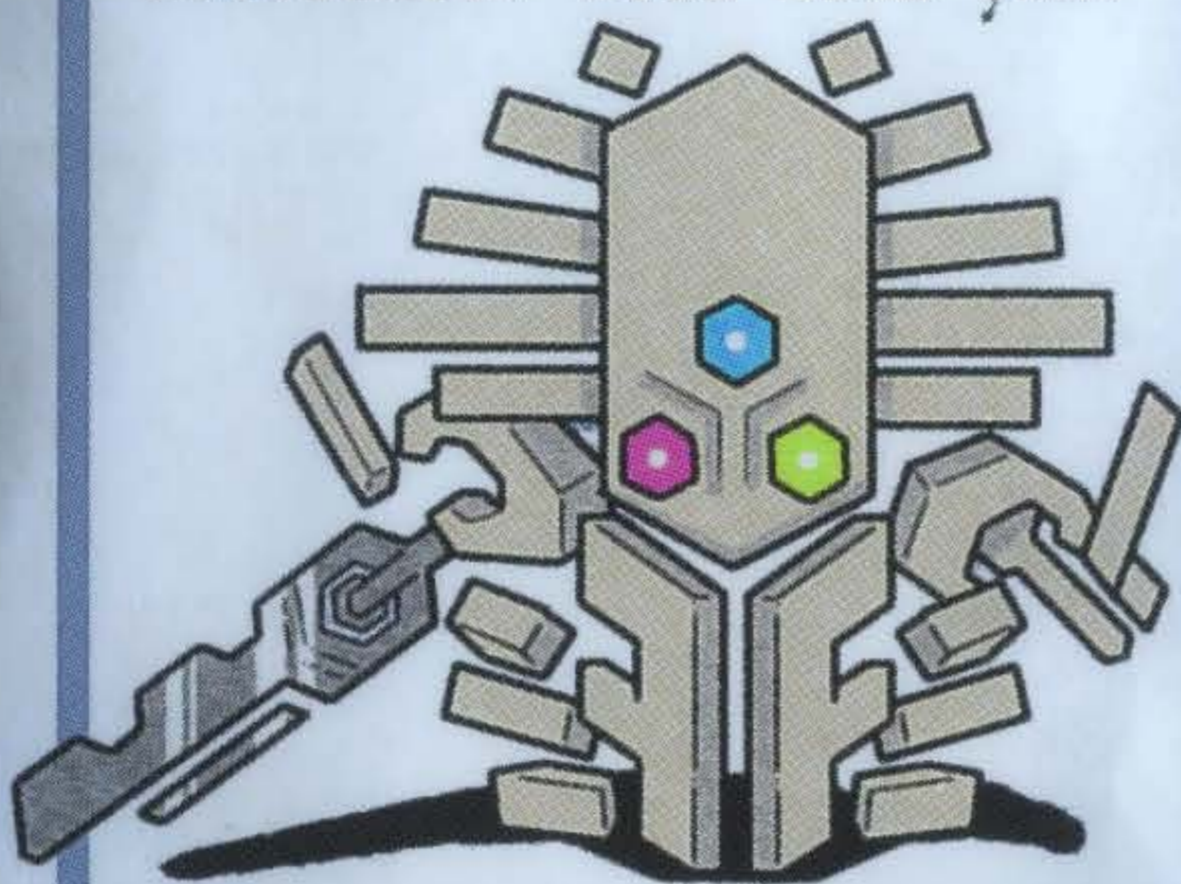

## MAGIC DAGGER

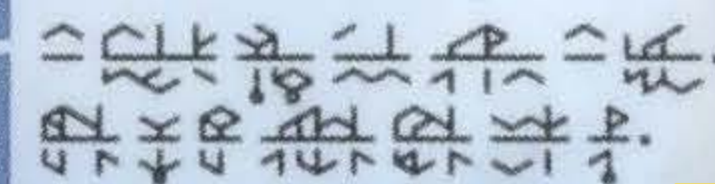

# OVERWORLD

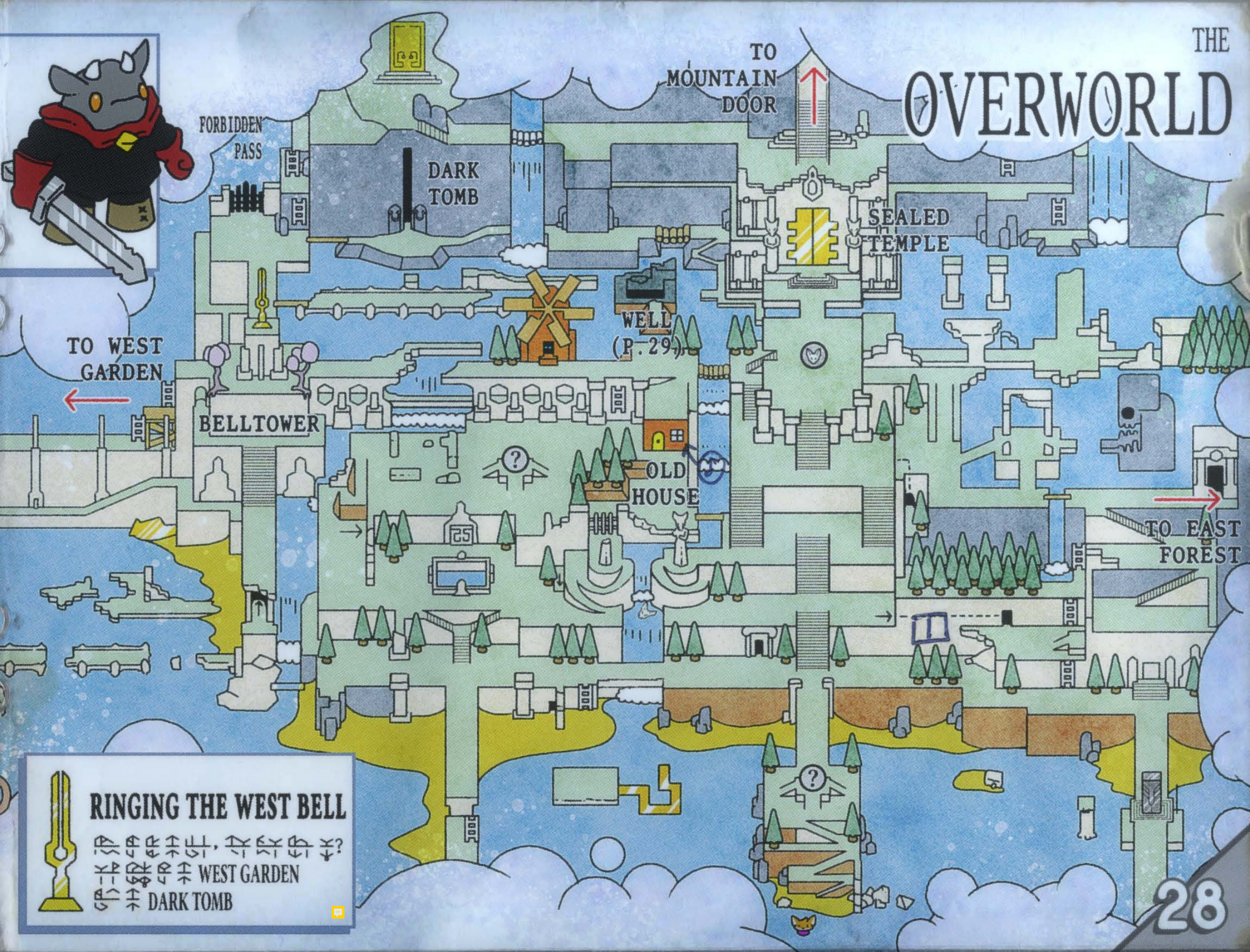

TO MOUNTAIN DOOR



FORBIDDEN PASS

DARK TOMB

SEALED TEMPLE

WELL (P. 29)

TO WEST GARDEN



BELLTOWER











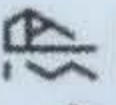
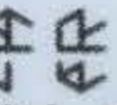
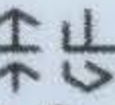
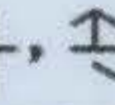
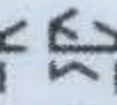
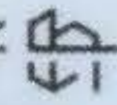















OLD HOUSE











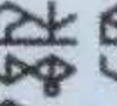



















TO EAST FOREST



**RINGING THE WEST BELL**



                              

WEST GARDEN

DARK TOMB

# UNDER THE WELL

1 2 3 4 5 6 7 8 9 10 11 12 13 14 15 16 17 18 19 20  
 21 22 23 24 25 26 27 28 29 30 31 32 33 34 35 36 37 38 39 40  
 41 42 43 44 45 46 47 48 49 50 51 52 53 54 55 56 57 58 59 60 61 62 63 64 65 66 67 68 69 70 71 72 73 74 75 76 77 78 79 80 81 82 83 84 85 86 87 88 89 90 91 92 93 94 95 96 97 98 99 100

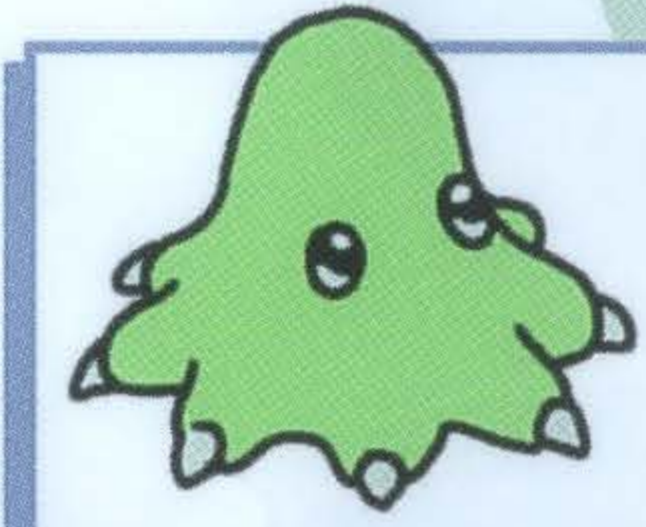
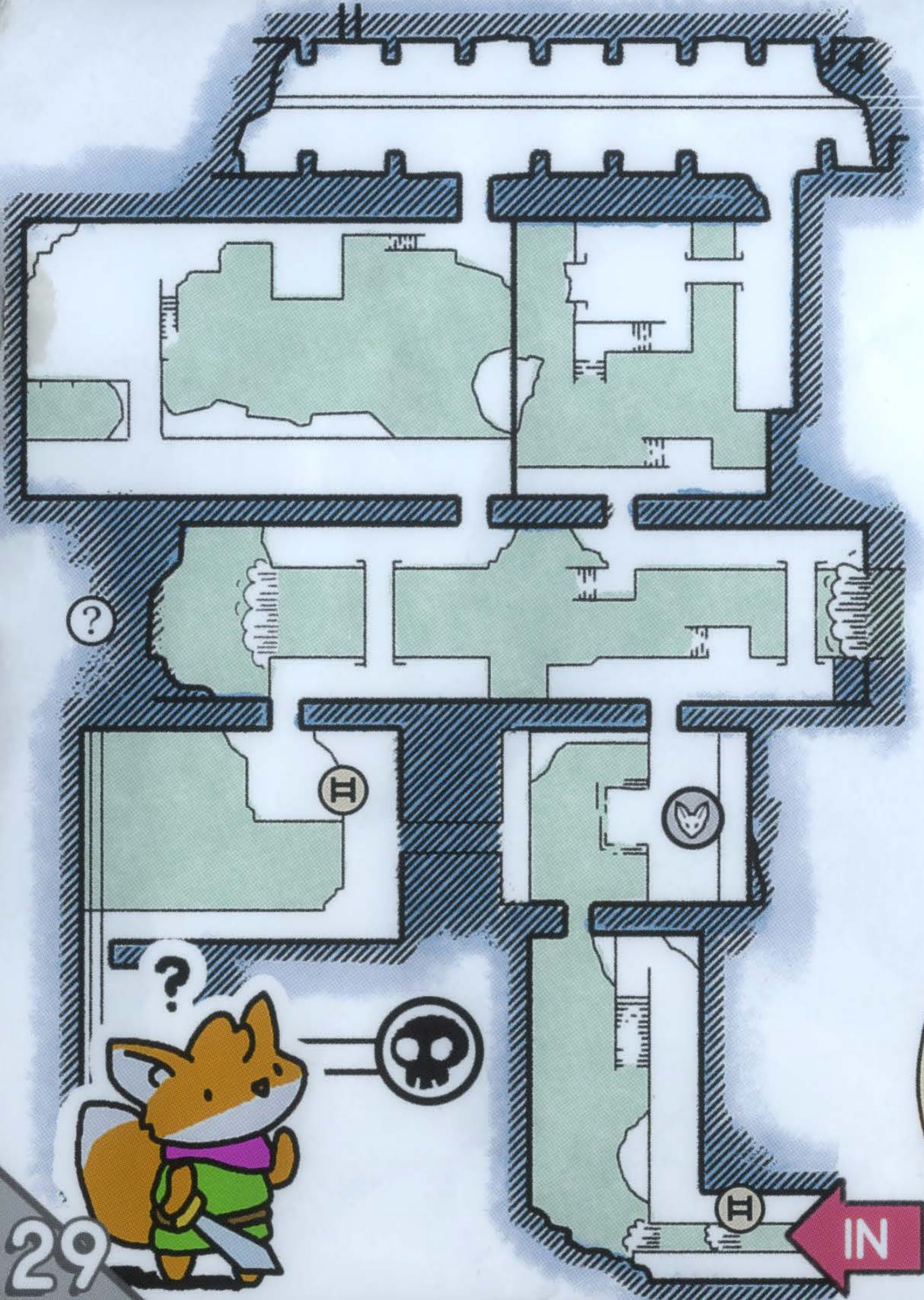

## SLORM

A type of slime who just wants to be close to you. Stun it by blocking.

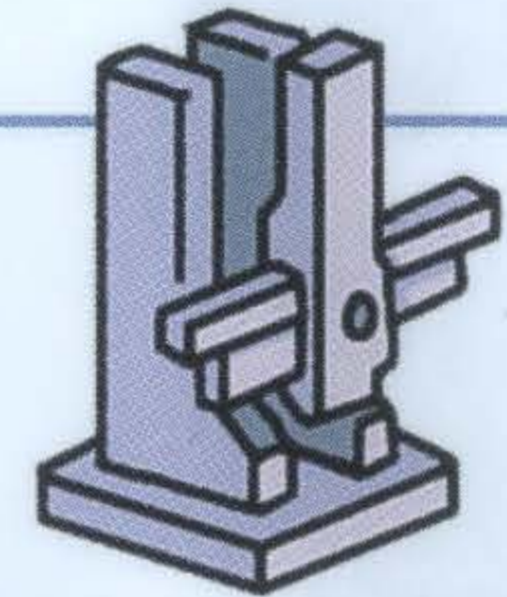

## AUTOBOLT

It wants to protect something, but what? Circle around and use the shield.

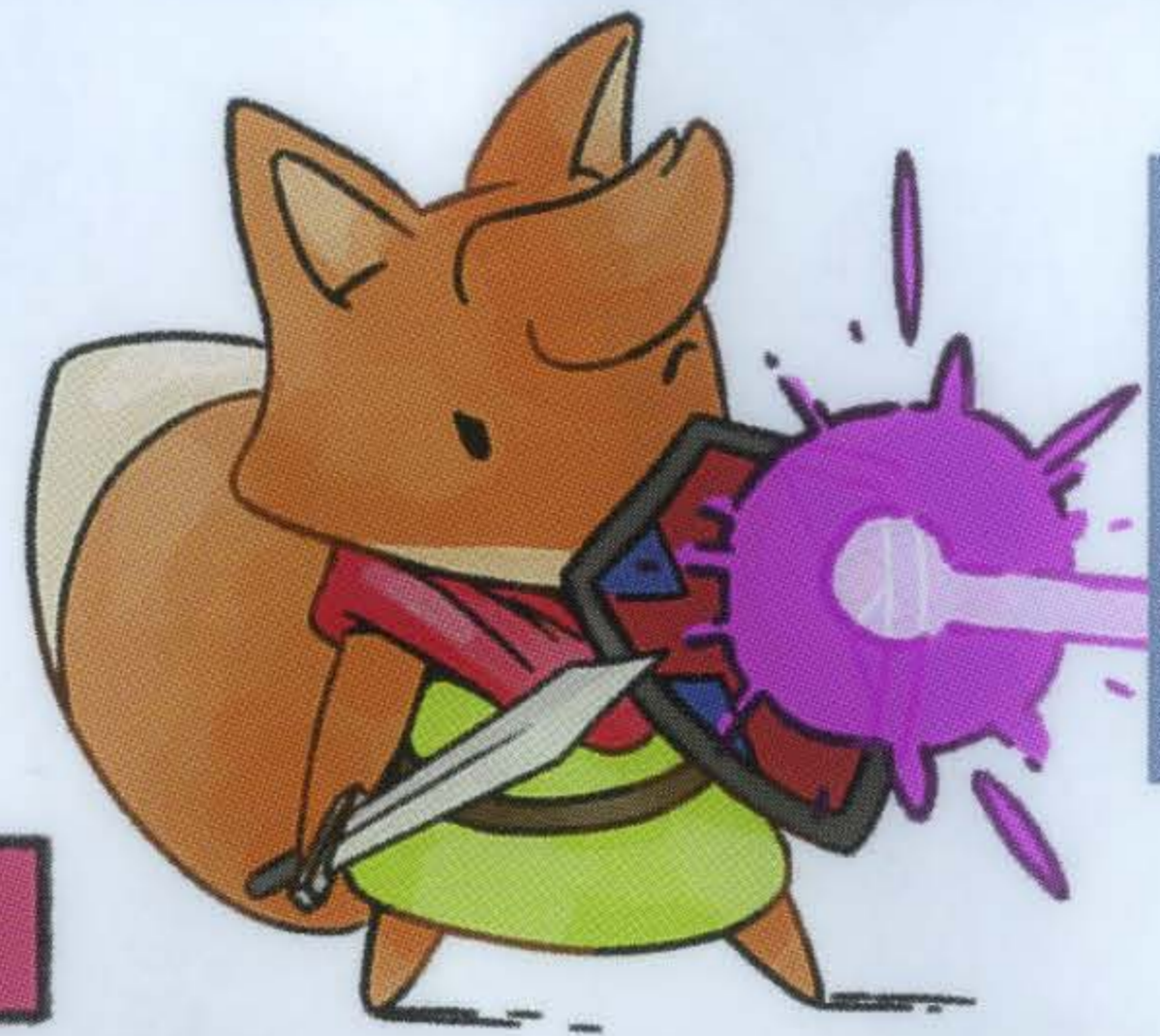

## TIP!



1 2 3 4 5 6 7 8 9 10 11 12 13 14 15 16 17 18 19 20  
 21 22 23 24 25 26 27 28 29 30 31 32 33 34 35 36 37 38 39 40  
 41 42 43 44 45 46 47 48 49 50 51 52 53 54 55 56 57 58 59 60 61 62 63 64 65 66 67 68 69 70 71 72 73 74 75 76 77 78 79 80 81 82 83 84 85 86 87 88 89 90 91 92 93 94 95 96 97 98 99 100







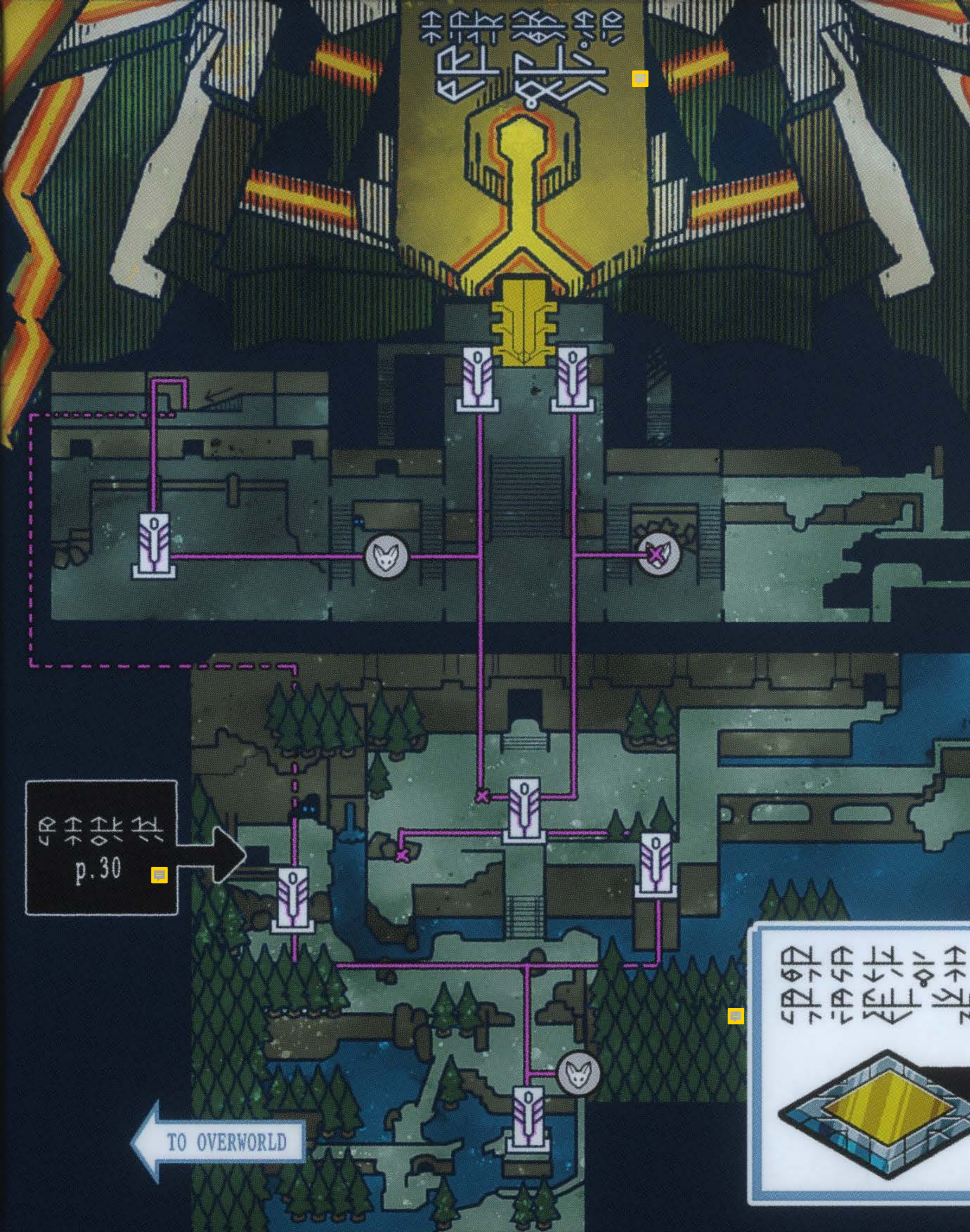

### CUSTODIANS

Caretakers of the Vault who have learned some magic. Candles can be put out.



### SPYRITE & SAPPHARACH

Don't be fooled! The mark on their backs is a trick.



p. 30

TO OVERWORLD



# THE RUINED ATOLL



𐌲𐌹𐌺𐌰 𐌹𐌺𐌰 𐌲𐌹𐌺𐌰 𐌹𐌺𐌰 𐌲𐌹𐌺𐌰 𐌹𐌺𐌰  
 𐌲𐌹𐌺𐌰 𐌹𐌺𐌰 𐌲𐌹𐌺𐌰 𐌹𐌺𐌰 𐌲𐌹𐌺𐌰 𐌹𐌺𐌰

𐌲𐌹𐌺𐌰, 𐌲𐌹𐌺𐌰 𐌲𐌹𐌺𐌰 𐌲𐌹𐌺𐌰 𐌲𐌹𐌺𐌰,  
 𐌲𐌹𐌺𐌰 𐌲𐌹𐌺𐌰 𐌲𐌹𐌺𐌰 𐌲𐌹𐌺𐌰.

𐌲𐌹𐌺𐌰 𐌲𐌹𐌺𐌰 𐌲𐌹𐌺𐌰 𐌲𐌹𐌺𐌰 𐌲𐌹𐌺𐌰,  
 𐌲𐌹𐌺𐌰 𐌲𐌹𐌺𐌰 𐌲𐌹𐌺𐌰 𐌲𐌹𐌺𐌰 𐌲𐌹𐌺𐌰...

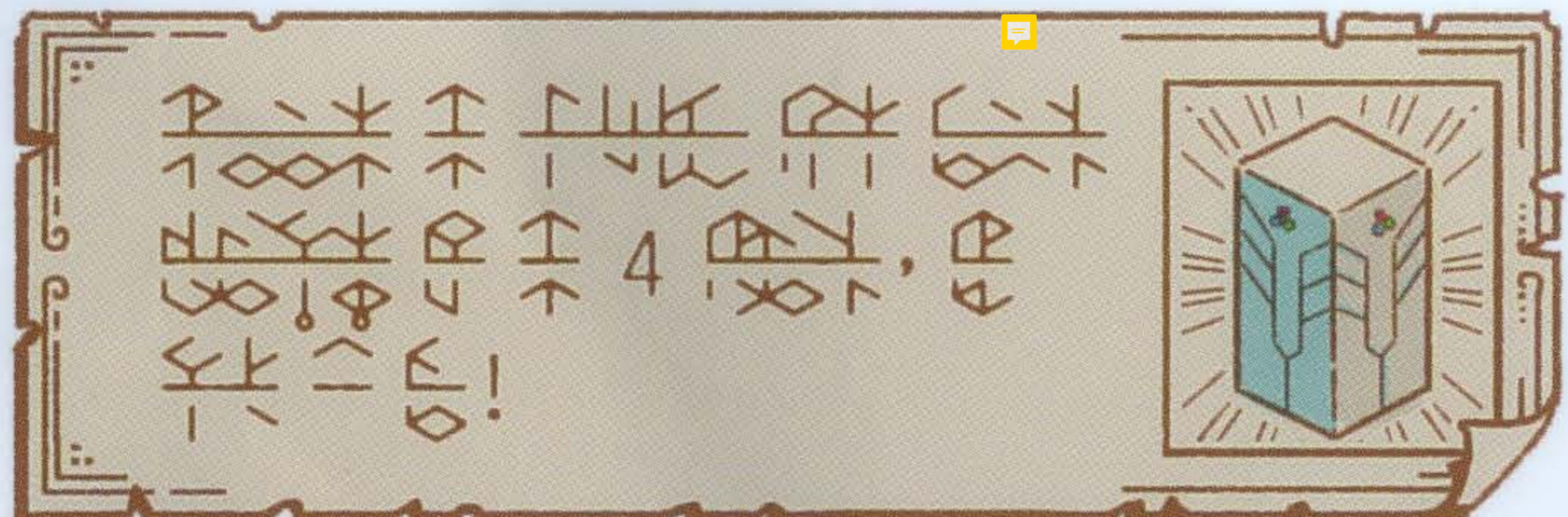



# HUSHER

A friendly bird that loves to eat slorms.



# CRABBO / CRABBIT

Crabbo has a hard shell, but crabbit has pals.



# ENVOY

More questions than answers.

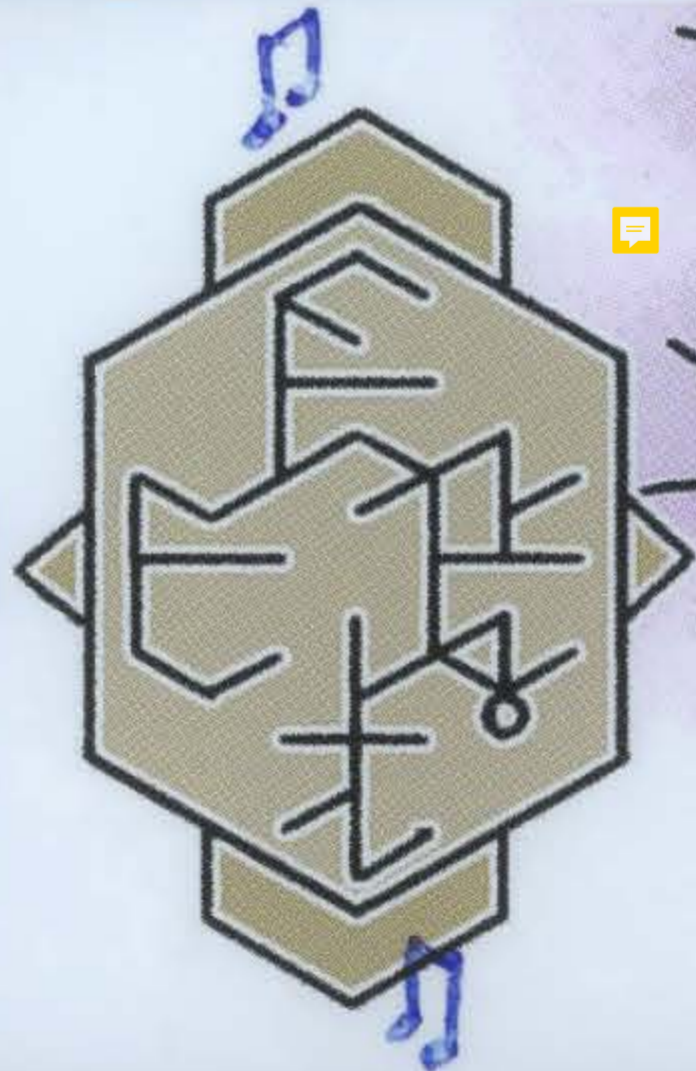

TO  
OVERWORLD

GATE

FROG'S  
DOMAIN

Still in training.  
They take turns  
attacking.



Grownups have hooks  
on their tongues.



Well equipped. Always  
tries to attack 3 times.



# THE FROG'S DOMAIN

A baby slorm who  
cannot spin yet, but  
is still useful.



MAGIC  
ORB





L... ..  
 ... ..  
 ... ..

THE LIBRARIAN ... ..  
 ... ..  
 ... ..  
 ... ..  
 ... ..

... ..  
 ... ..  
 ... ..  
 ... ..  
 ... ..

... ..  
 ... ..



# BOSS OF THE SCAVENGERS

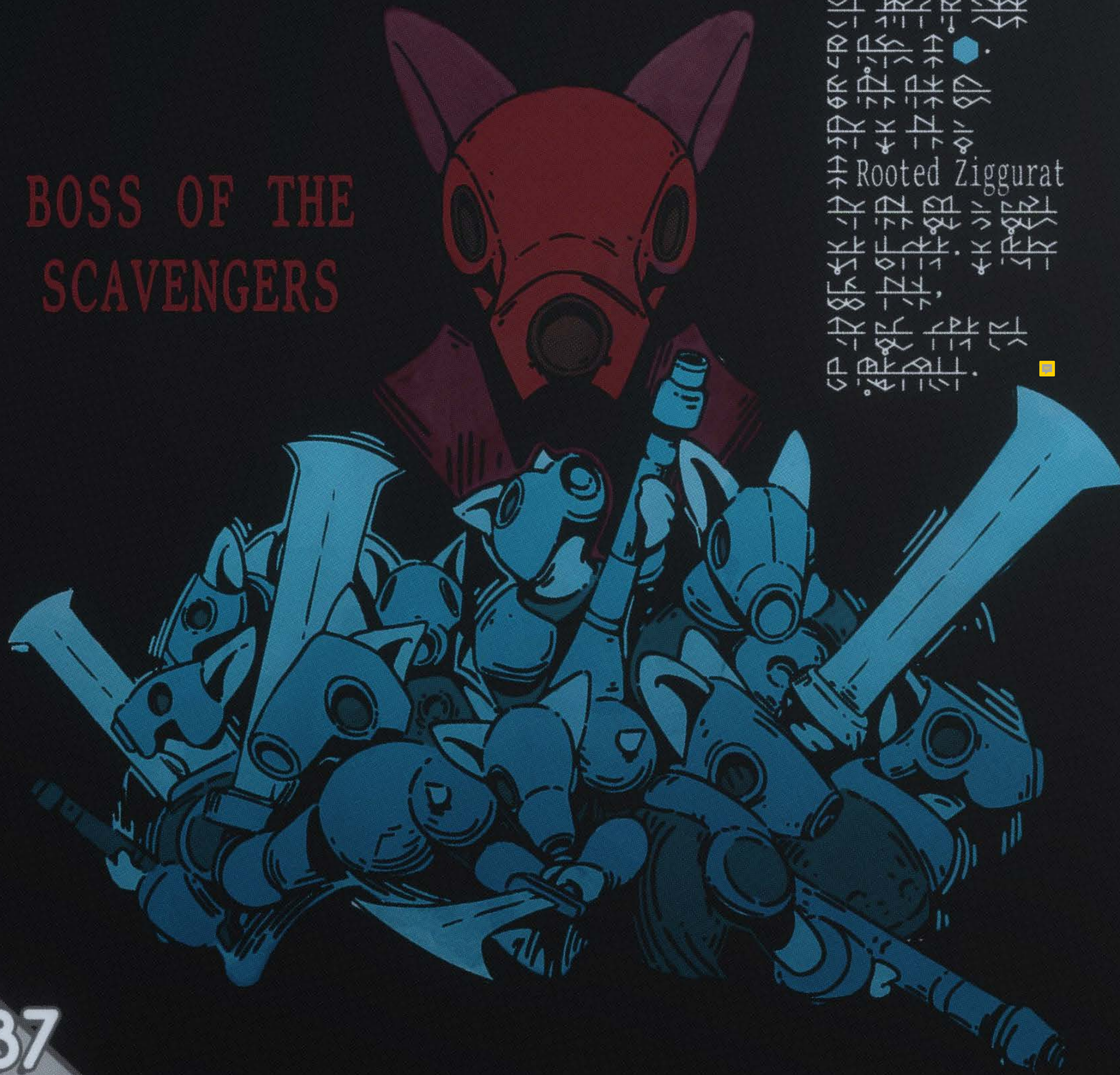

Rooted Ziggurat

## RIFLE

Built out of autobolt parts, but can only shoot once. Scavengers with this will try to keep their distance.

## MINER'S GREATSWORD

Beefy scavengers use this to crack open odd architecture and you.

## BOMBS

Watch out for miners who use these. They try not to hurt their allies but accidents happen.



# FLEEMERS

〰〰〰 〰 〰〰〰 〰 〰.  
 〰〰〰 〰 〰〰〰 〰 〰.  
 〰〰〰 〰 〰〰〰 〰 〰.  
 〰〰〰 〰 〰〰〰 〰 〰.  
 〰〰〰 〰 〰〰〰 〰 〰.

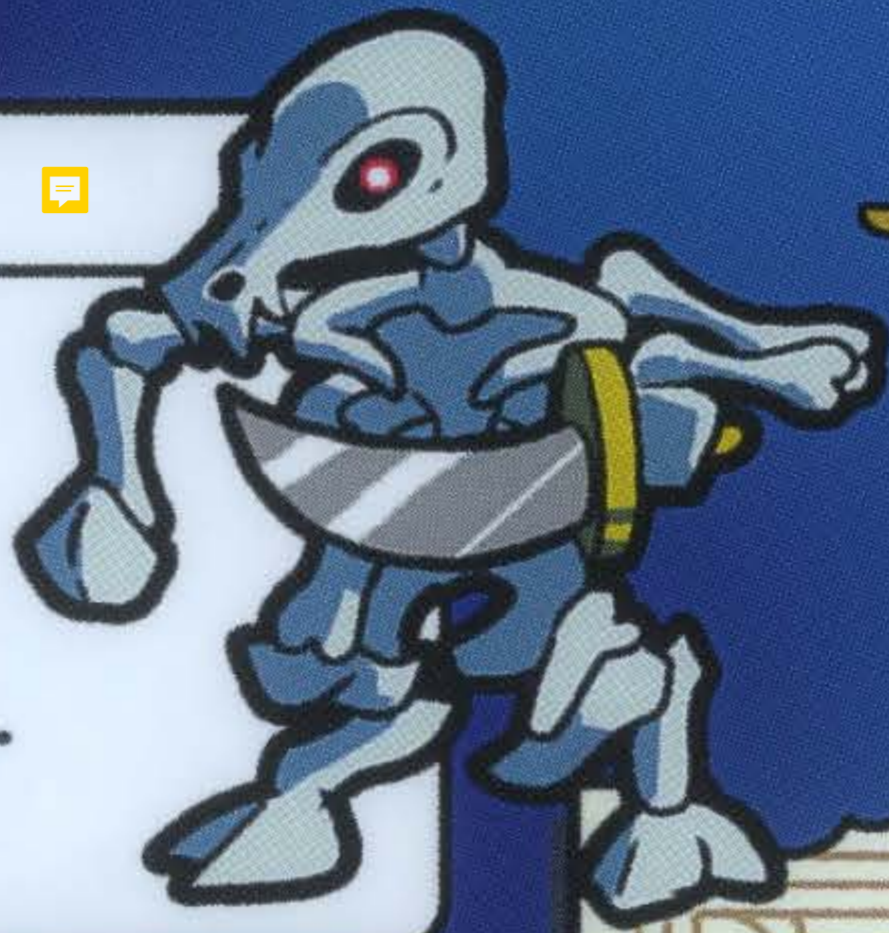

This zone is extremely dangerous and is best left alone, even if you're feeling brave. Only ghosts are permitted to enter the Inner Grounds.



# PHREND

〰 〰〰〰 〰〰〰 〰 〰.  
 〰 〰〰〰 〰〰〰 〰 〰.  
 〰 〰〰〰 〰〰〰 〰 〰.  
 〰 〰〰〰 〰〰〰 〰 〰.



〰 〰〰〰 〰〰〰 〰 〰.  
 〰 〰〰〰 〰〰〰 〰 〰.  
 〰 〰〰〰 〰〰〰 〰 〰.  
 〰 〰〰〰 〰〰〰 〰 〰.

# LOST ECHO

ECHO-OF-SELF  
 〰 〰〰〰 〰〰〰 〰 〰.  
 〰 〰〰〰 〰〰〰 〰 〰.  
 〰 〰〰〰 〰〰〰 〰 〰.  
 〰 〰〰〰 〰〰〰 〰 〰.



# THE SWAMP

## OLD BURYING GROUND

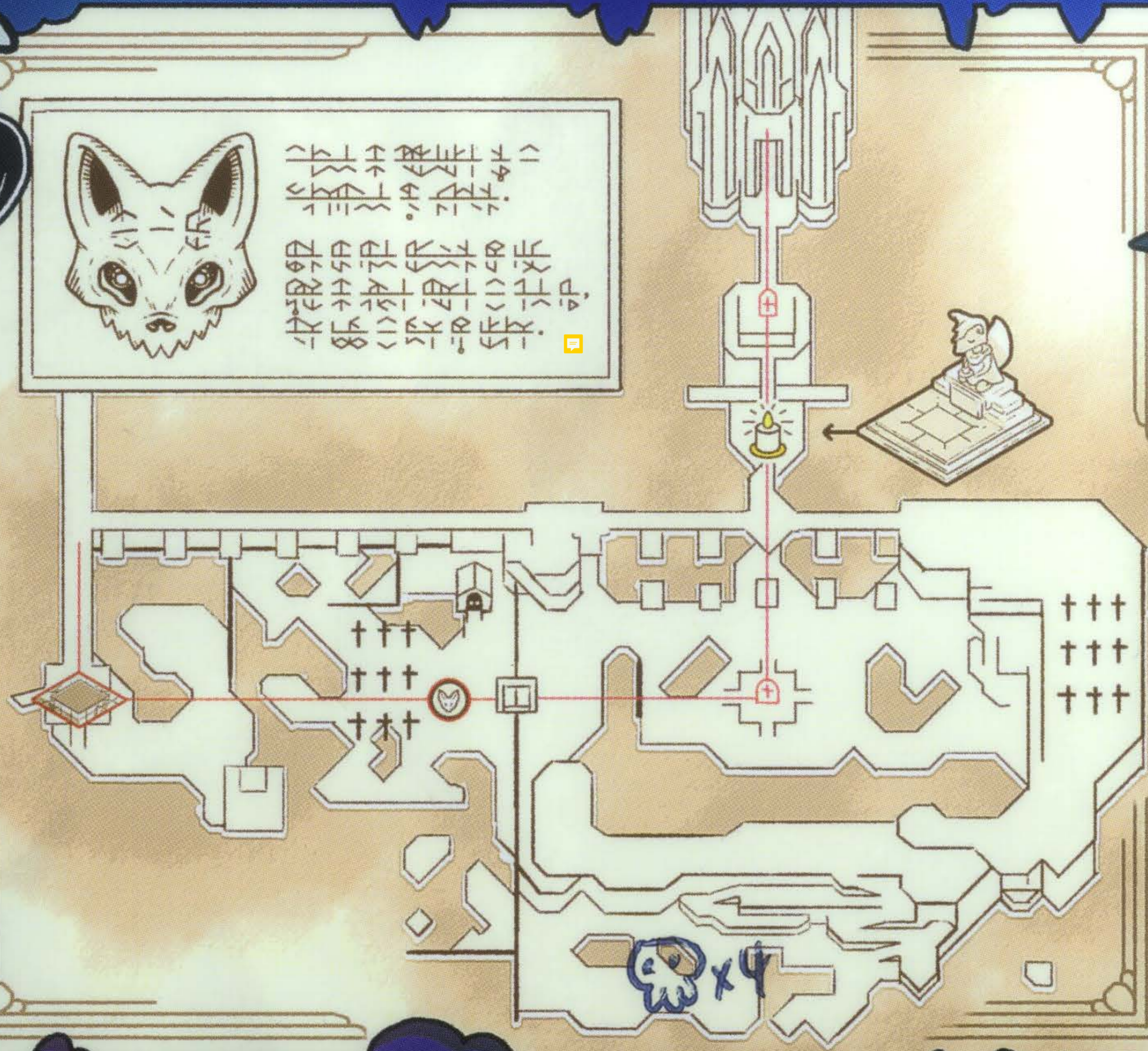







QUARRY



WEST GARDEN



RUINED ATOLL



RUINED ATOLL



EASTERN VAULT



TOWN RUINS



TOWN RUINS



TOWN RUINS



**HP**  
3

**NORMAL**

**HP**  
1

**幽霊/GHOST**







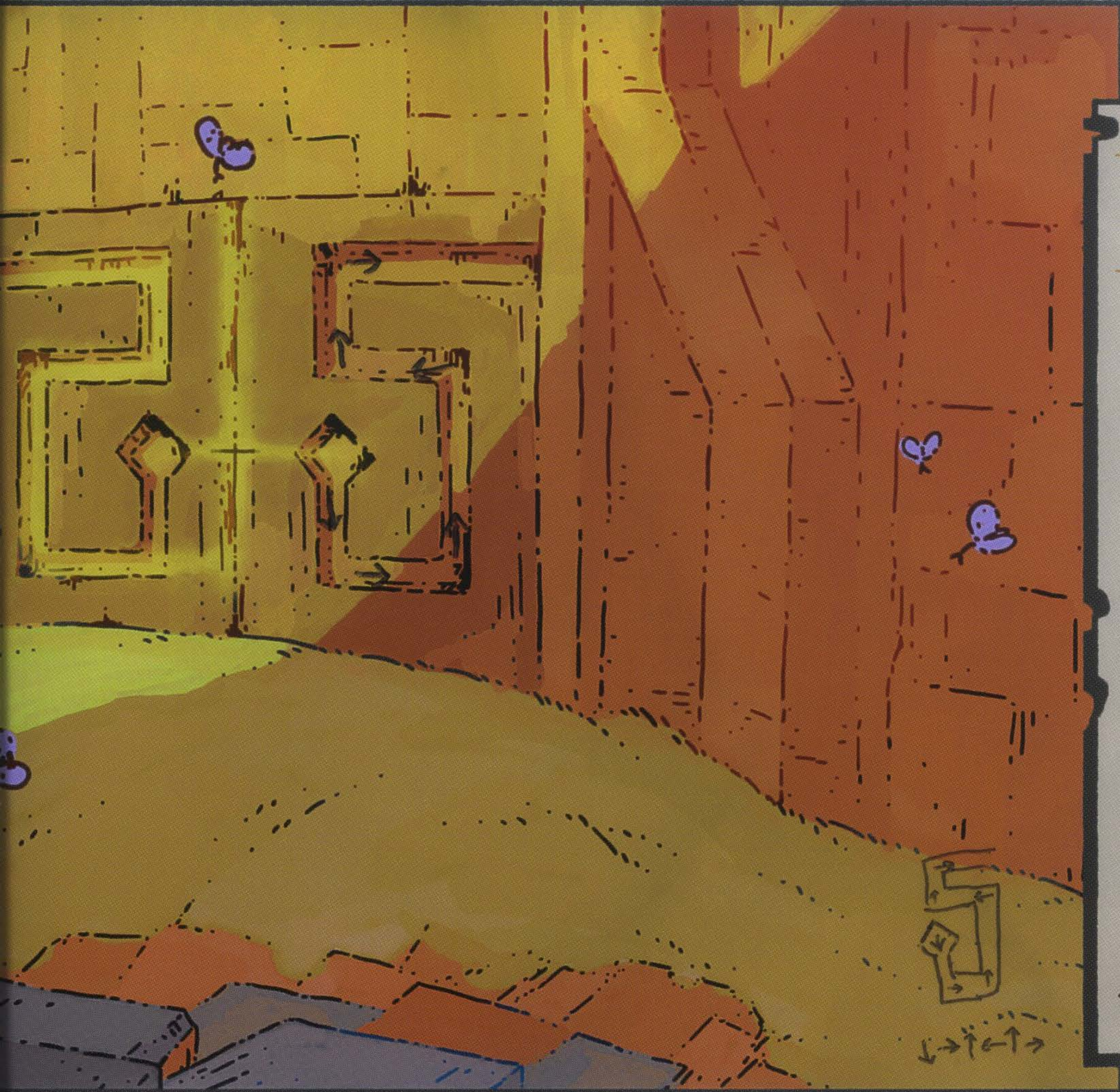

**HP**  
2





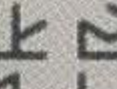
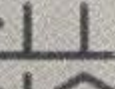
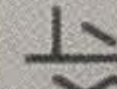
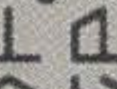
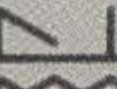

P. 23



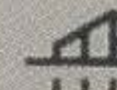
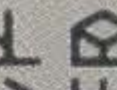

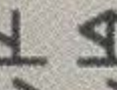



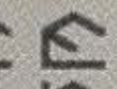
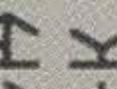
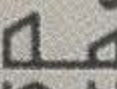
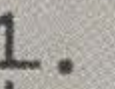

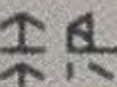
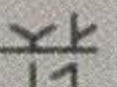
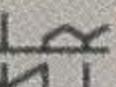
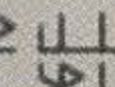

# Hidden Secrets





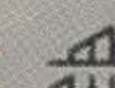
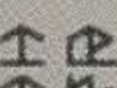
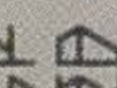
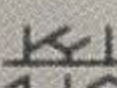
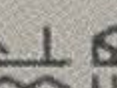
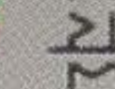
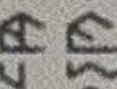
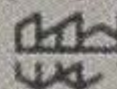
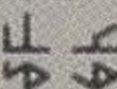
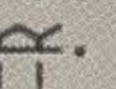





  

 HOLY CROSS



 THE GOLDEN PATH





 OVERWORLD

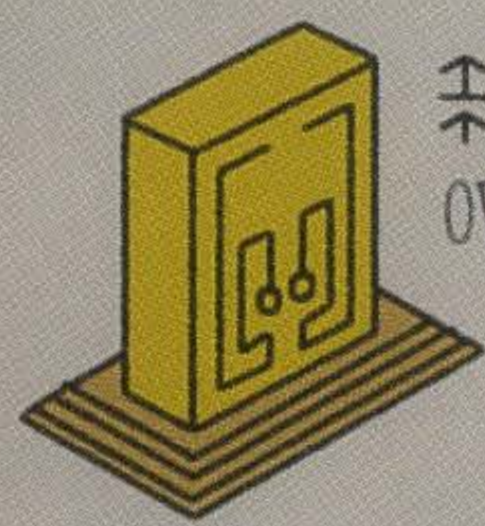



or Seeking An End

SHARE YOUR WISDOM

B

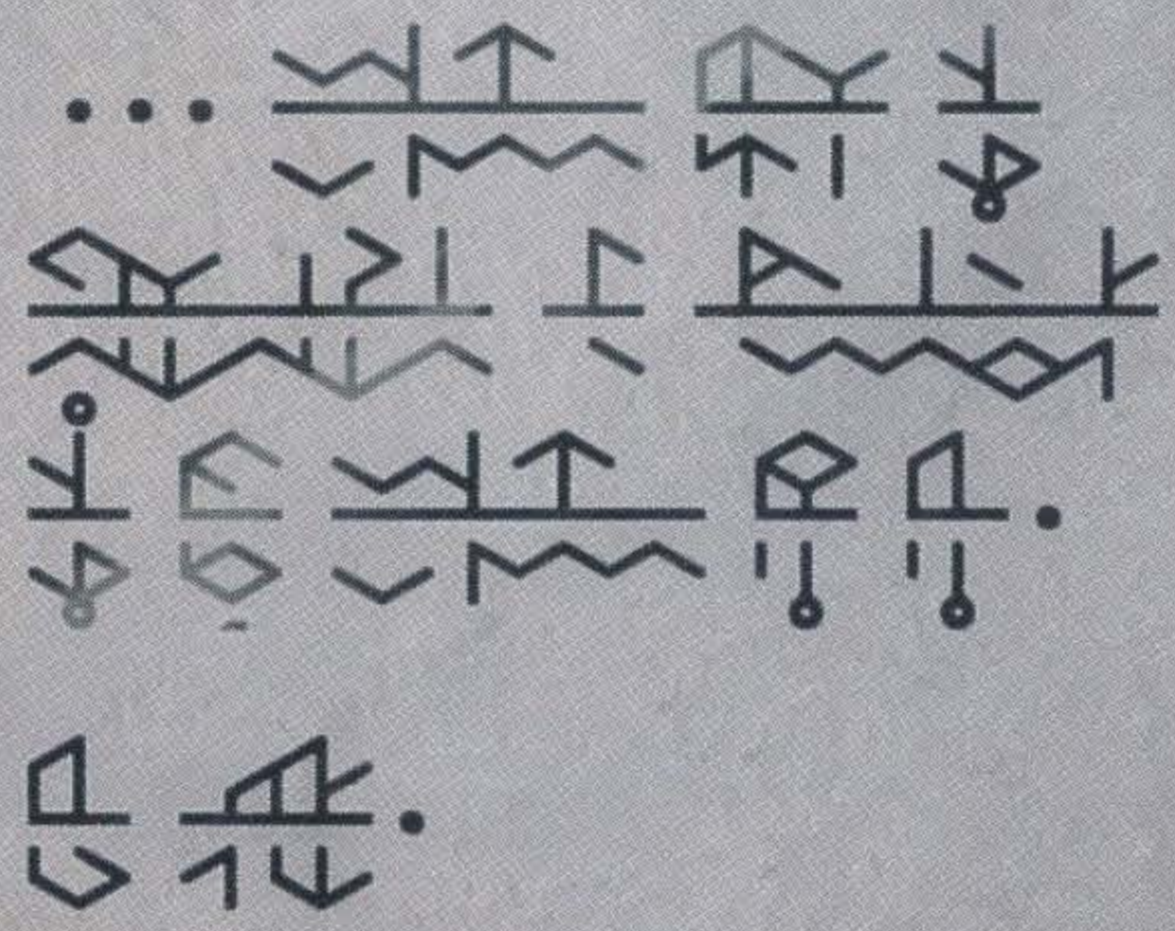

Use the power of the Holy Cross  
and traverse the Golden Path

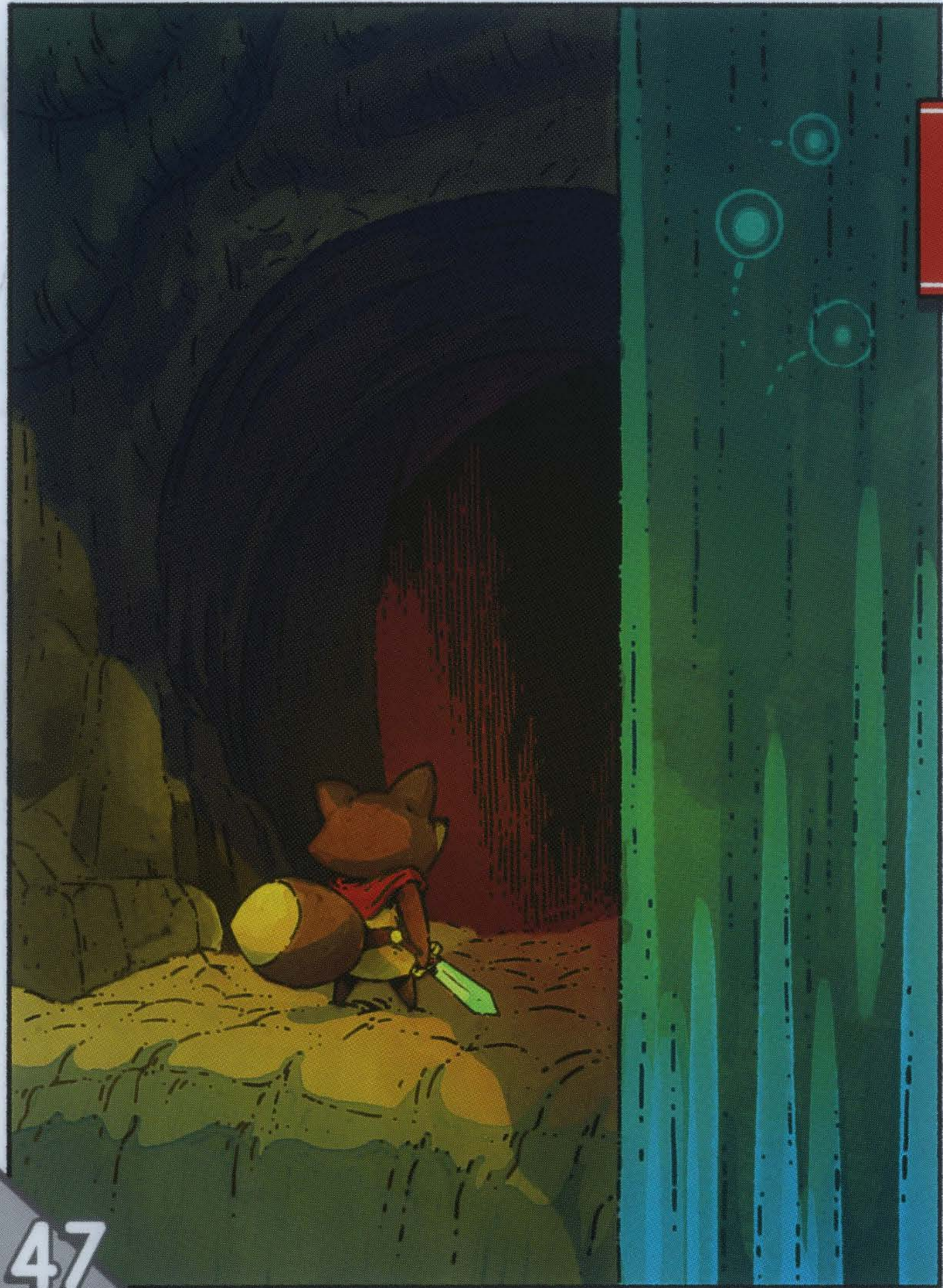

# THE FAIR

FA PLY ^ OX ZI P FA  
 A T PL . 1 PK LFKZL  
 PLT SJK, ZJK ^ HLF PA  
 EE SA PL T P A A HOLY CROSS.

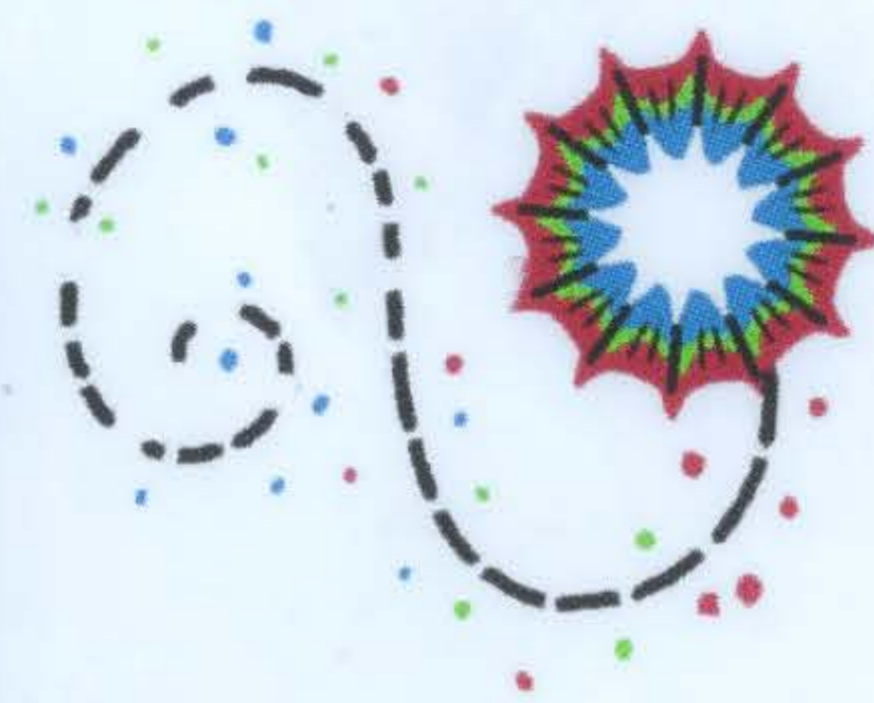

^ PL FA < T PL S PL ^  
 KFK A PLT . 1 ZJK ^  
 ZJK PLT PL PL PL PL  
 PLT . PL ^ PL PL PL ^  
 PLK PL PL PL PL PL

## SEEKING-SPELL

X PLK LA < T P PL PL  
 T PL PL A PL PL PL PL  
 PL PL PL PL PL PL PL





# Y SPRING



## SECRET GATHERING PLACE

𐄂 𐄂 𐄂 𐄂 𐄂 ?  
 𐄂 𐄂 𐄂 𐄂 𐄂 𐄂 𐄂  
 𐄂 𐄂 𐄂 𐄂 𐄂 𐄂 𐄂

𐄂 𐄂 𐄂 𐄂 𐄂 𐄂  
 "FINAL" TREASURE 𐄂  
 𐄂 𐄂 𐄂 𐄂 𐄂 𐄂  
 𐄂 𐄂 𐄂 𐄂 𐄂 𐄂

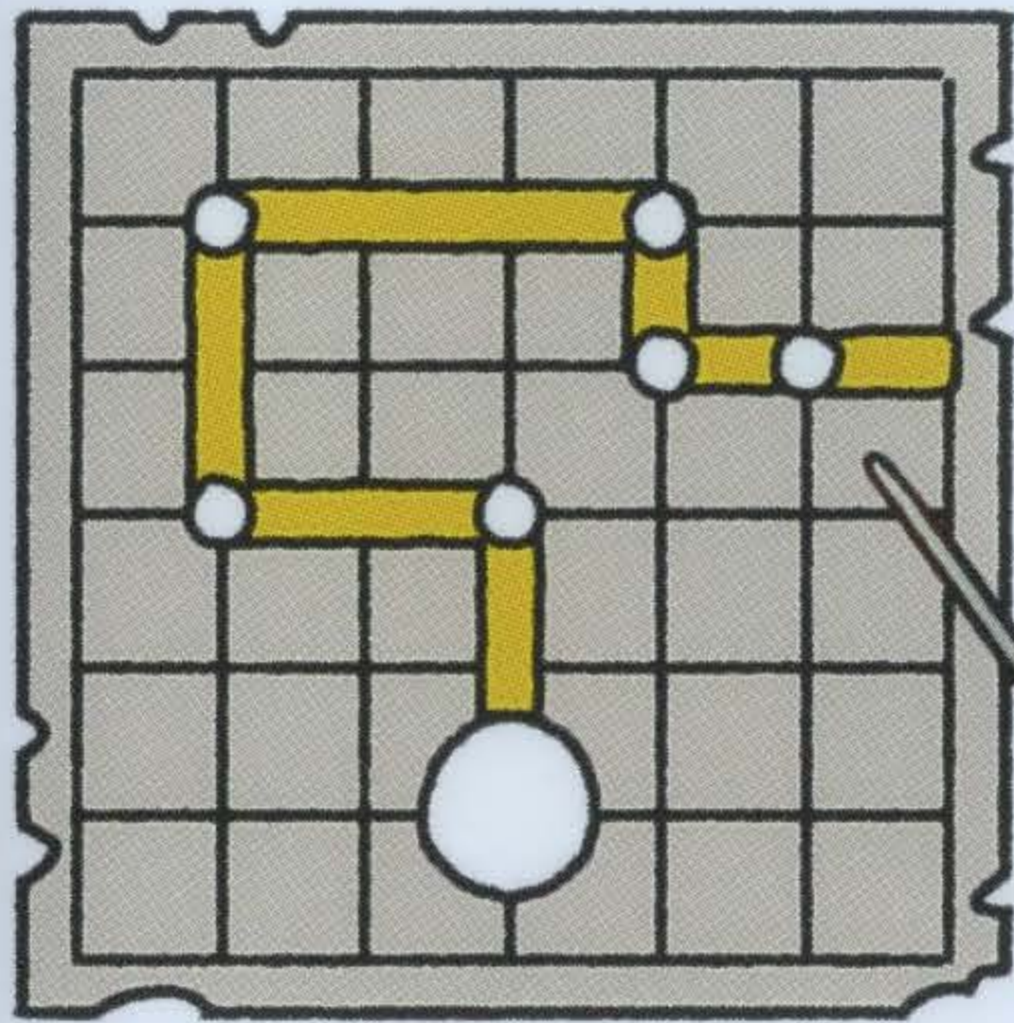

𐄂 𐄂 𐄂 𐄂 𐄂 ?  
 𐄂 𐄂 𐄂 𐄂 𐄂 ?

|                          |                        |                                     |                               |
|--------------------------|------------------------|-------------------------------------|-------------------------------|
| <input type="checkbox"/> | 𐄂 𐄂 𐄂 1                | <input type="checkbox"/>            | 𐄂 𐄂                           |
| <input type="checkbox"/> | 𐄂 𐄂 𐄂 2                | <input checked="" type="checkbox"/> | 𐄂 𐄂 (𐄂)                       |
| <input type="checkbox"/> | 𐄂 𐄂                    | <input type="checkbox"/>            | 𐄂 𐄂                           |
| <input type="checkbox"/> | 𐄂 𐄂 𐄂 𐄂                | <input type="checkbox"/>            | 𐄂 𐄂                           |
| <input type="checkbox"/> | SECRET GATHERING PLACE | <input type="checkbox"/>            | 𐄂 𐄂 (𐄂 𐄂)                     |
| <input type="checkbox"/> | SEALED TEMPLE          | <input type="checkbox"/>            | 𐄂 𐄂                           |
| <input type="checkbox"/> | THE QUARRY             | <input type="checkbox"/>            | WEST GARDEN                   |
| <input type="checkbox"/> | EAST FOREST            | <input type="checkbox"/>            | WEST GARDEN                   |
| <input type="checkbox"/> | THE GREAT LIBRARY      | <input type="checkbox"/>            | FORTRESS OF THE EASTERN VAULT |
| <input type="checkbox"/> | 𐄂 𐄂 (𐄂)                | <input type="checkbox"/>            | EAST FOREST                   |

100%

48 11 2 6 52

27 21 4 50 42

15 22 55 31 33

46 28 9 40 18

34 16 12 39 44

↑ 6 11 16 21 26 31

↑ 11 16 21 26 31



# The Door In The Mountains



# 茶

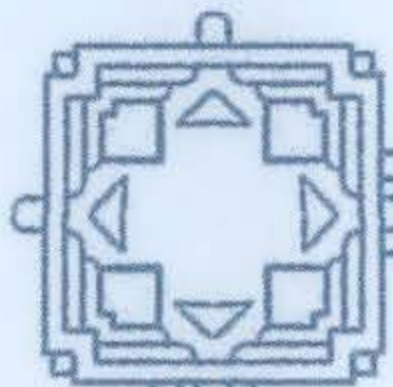

ORANGE PERIL RING



CYAN PERIL RING



INVERTED ASH



ANKLET



PERFUME



TINCTURE



BRACER



LUCKY CUP



MUFFLING BELL



LOUDER ECHO

x4



SCAVENGER'S MASK



DAGGER STRAP



MAGIC ECHO



???

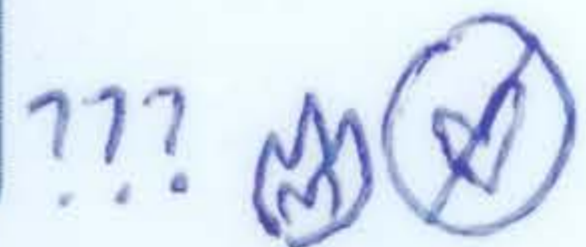

AURA'S GEM



Shhh...

60 seconds

★

# MEMO

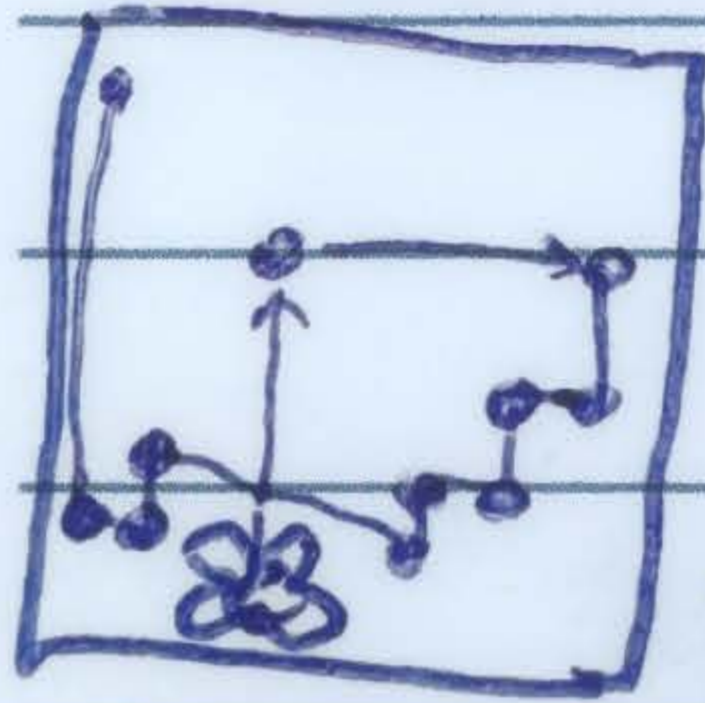
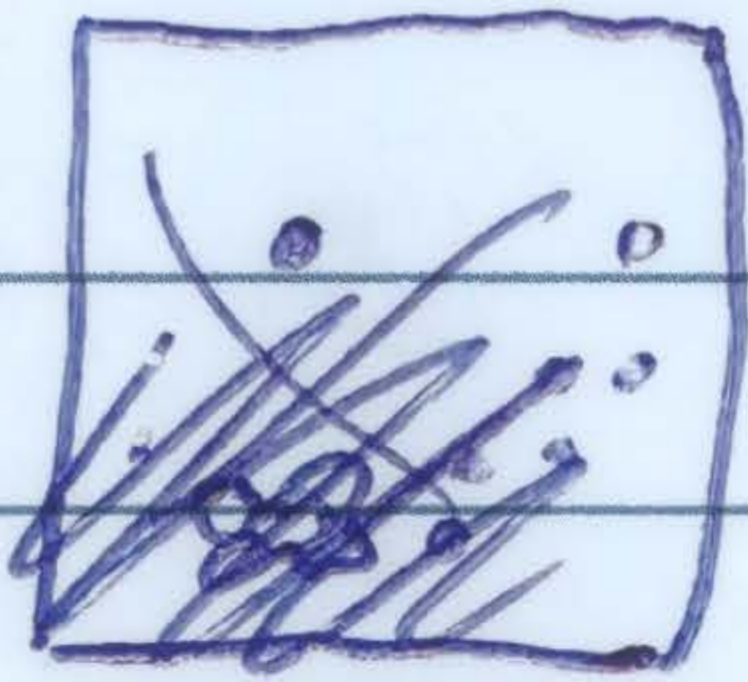
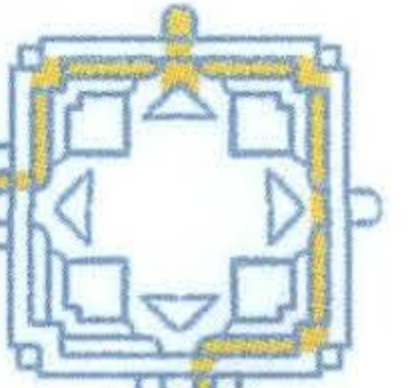

↑ ↓ ↖ ↗ ↘ ↙ ↘ ↙ ↘ ↙

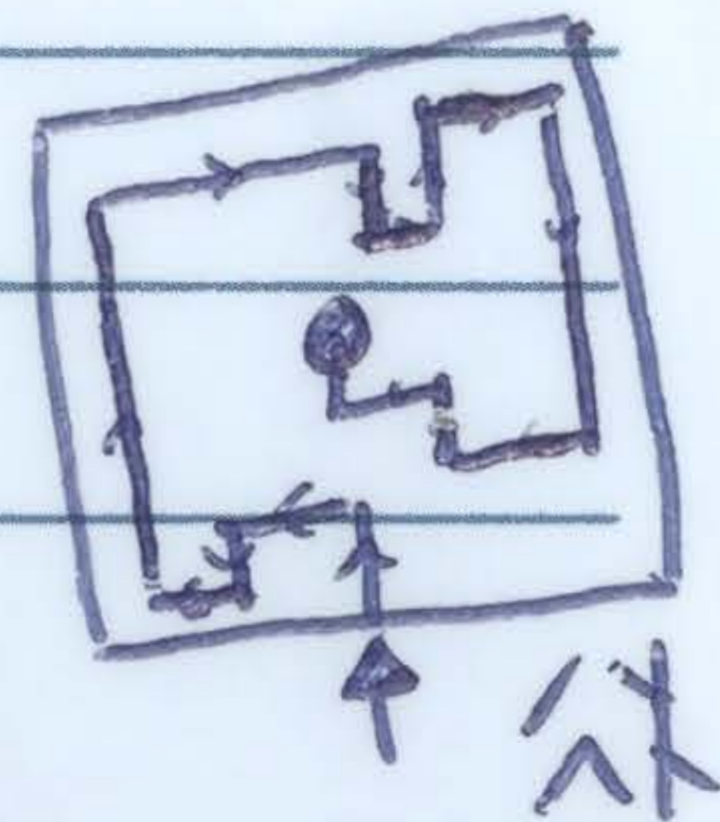
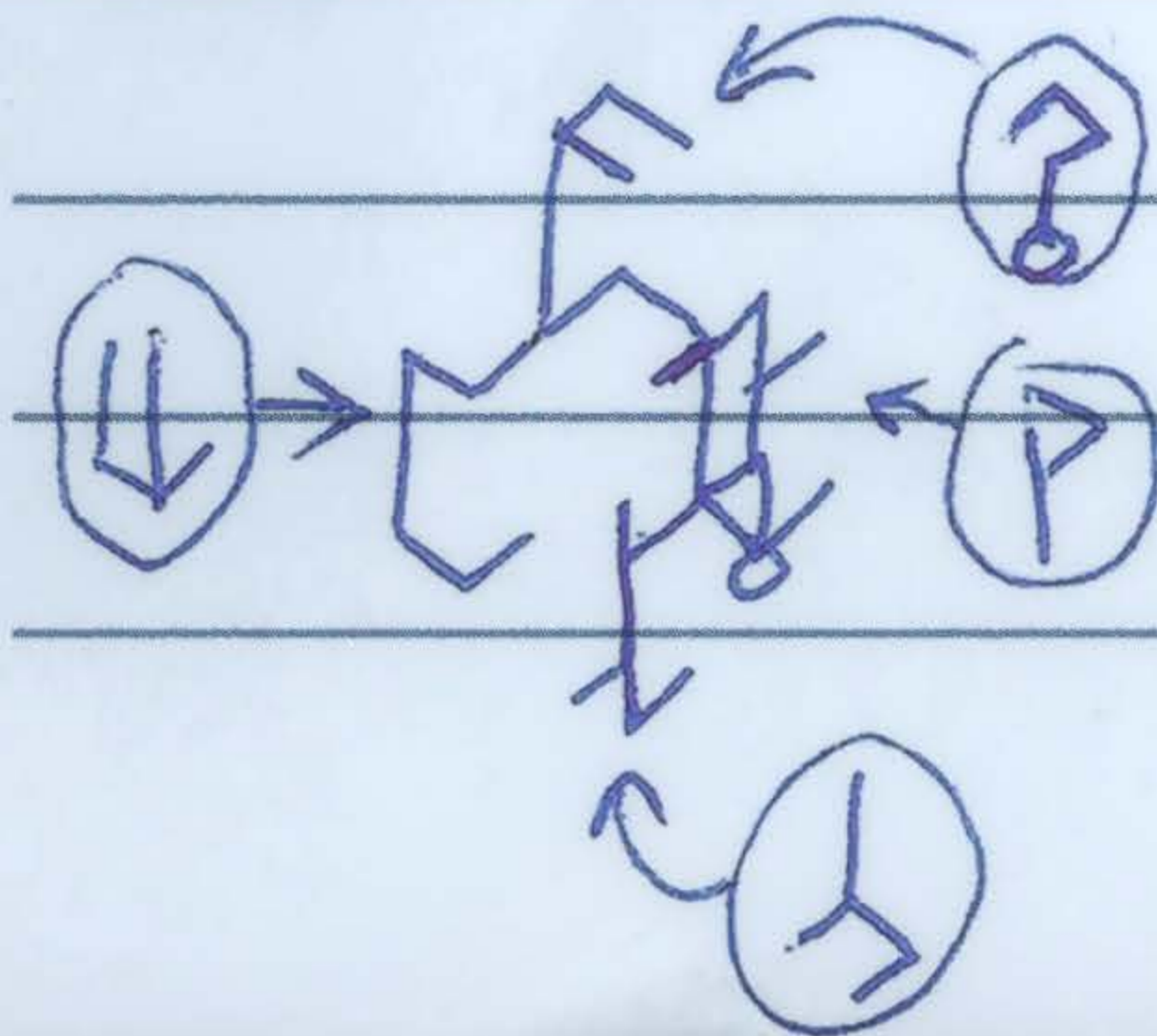
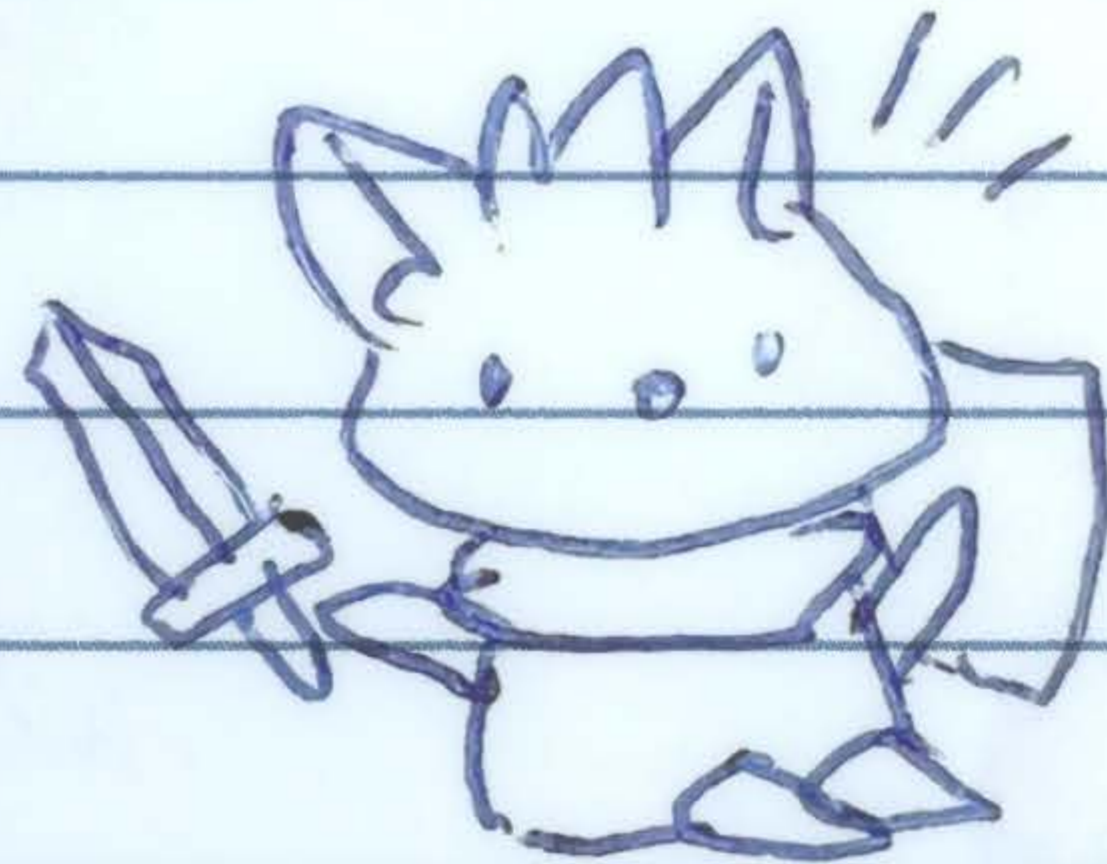

# MEMO

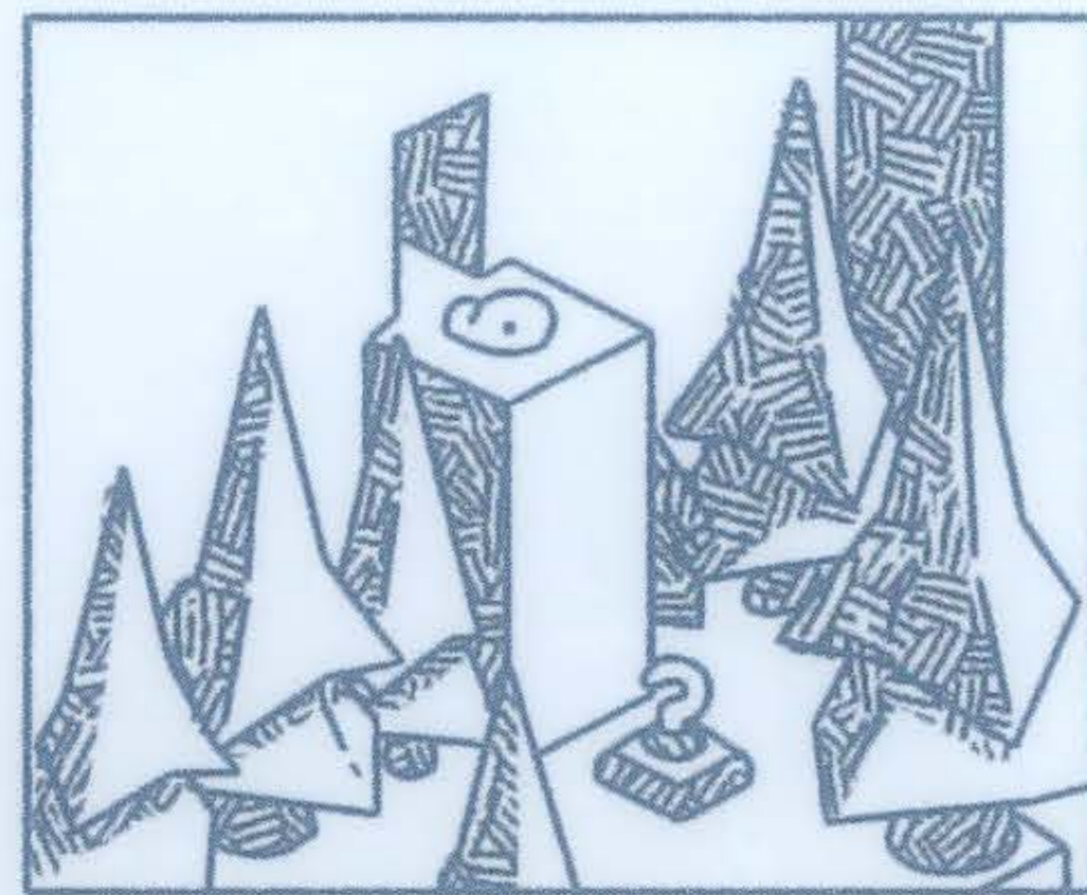
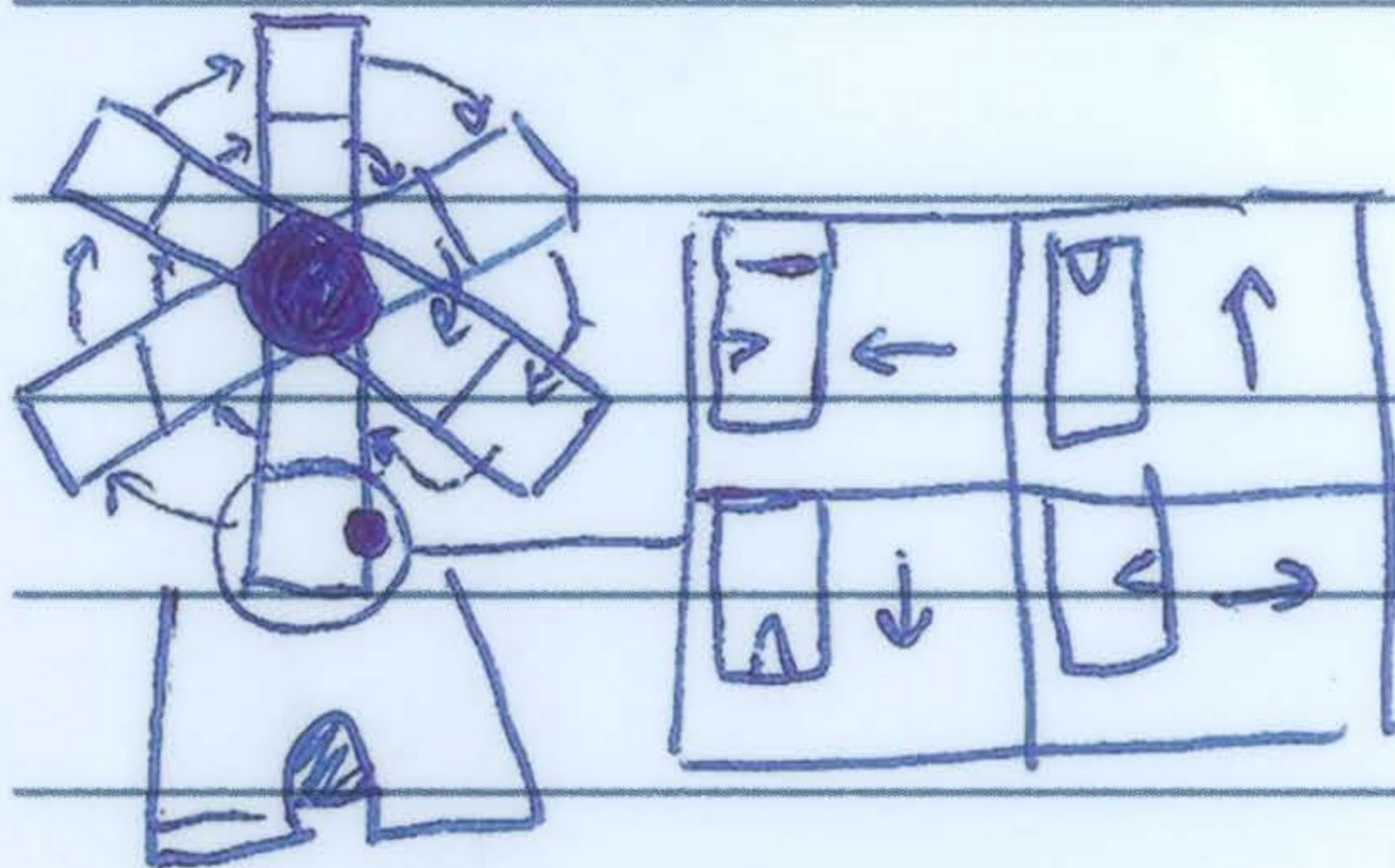
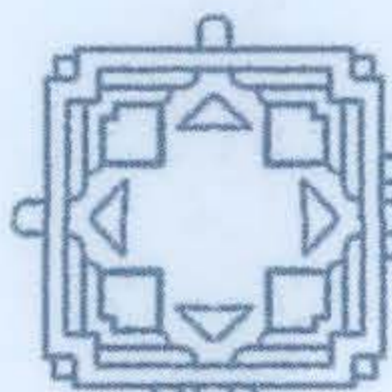

# MEMO

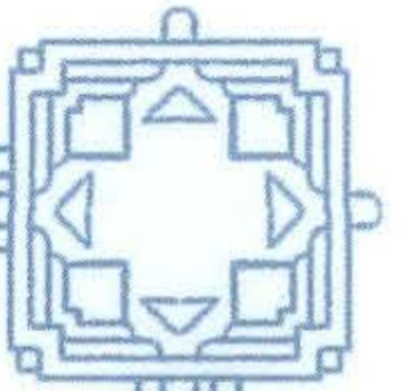

Handwritten symbols on lined paper:

- Row 1: Six upward-pointing shapes, followed by a bracketed symbol.
- Row 2: Six downward-pointing shapes, followed by a bracketed symbol, a cat face, and a small square.
- Row 3: Six circular shapes, followed by a bracketed symbol and a small square.
- Row 4: A 2x6 grid of various symbols, followed by a bracketed symbol and a small square.
- Row 5: A 2x6 grid of various symbols, followed by a small square.

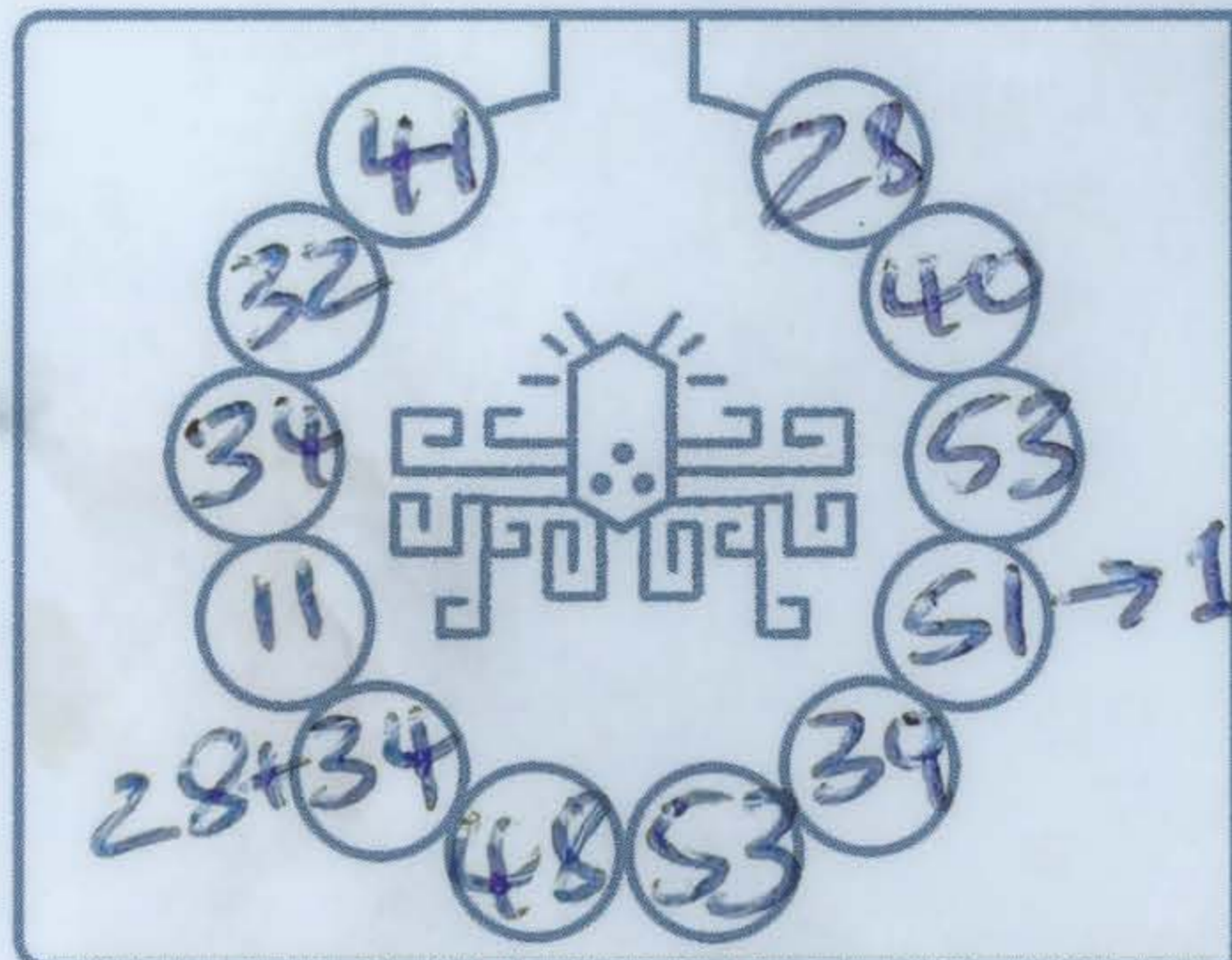

## FOR ADDITIONAL SUPPORT & SECRETS

1. □
- 2.
- 3.

